

# Layla<sup>®</sup> by echo<sup>®</sup>

## **Owner's Manual Version 1.6 for PC**

Layla is designed and manufactured in the U.S. by Echo Corporation

## **Important Safety Instructions**

**1. Read Instructions** - Be sure to read all of the safety and operating instructions before operating this product.

**2. Retain Instructions** - The safety instructions and owner's manual should be retained for future reference.

**3. Heed Warnings** - All warnings on Layla and in the Owner's Manual should be followed.

**4. Follow Instructions** - All operating and use instructions should be followed.

**5. Moisture** - Water and moisture are detrimental to the continued good health of Layla. Do not install or operate Layla near sources of water or moisture such as sinks, damp basements, leaky roofs, etc.

**6. Heat** - Layla should be situated away from sources of heat such as heaters or radiators.

**7. Power Sources** - This unit should be operated only from the type of power source indicated in this documentation or on Layla. If you are unsure about the type of power at your location, contact your local power company.

**8. Grounding** - Precautions should be taken so that the grounding capabilities of the Layla are not undermined. This equipment is provided with a cord having an equipment grounding conductor and grounding plug. This plug must be plugged into an outlet that is properly installed and grounded in accordance with all local rules and ordinances. Do not modify the plug provided with the equipment. If the plug will not fit into your outlet, have a proper outlet installed by a qualified electrician.

**9. Power Cord Protection** - Power supply cords should be routed so that they are unlikely to be walked on or pinched by items placed upon or against them. Pay particular attention to protecting the plugs, outlets, and the point at which the cord exits Layla.

**10. Servicing** - Do not attempt to service this unit yourself, as opening the case will expose you to hazardous voltage or other dangers. All servicing should be referred to qualified service personnel.

**11. Damage Requiring Service** - Unplug this unit and refer it to a qualified service technician when any of the following occur:

- a) Objects have fallen or liquid has spilled into the unit
- b) The product has been exposed to rain or water
- c) The product does not operate normally or when a marked change in performance is noticed
- d) The product has been dropped or damaged in any way

Sending in your registration card – or registering online at <http://www.echoaudio.com/register.html> - allows us to register key information so that we may handle problems faster and inform you of advance information on upgrades and other news. Thanks in advance for filling out your registration card and sending it to us. We hope you enjoy your Echo product.

## Limited Warranty

Echo Corporation warrants this product, when purchased at an Authorized Echo Dealer in the United States of America, to be free of defects in materials and manufacturing workmanship for a period of one year from the date of original purchase. During the warranty period Echo shall, at its option, either repair or replace any product that proves to be defective upon inspection by Echo. Final determination of warranty coverage lies solely with Echo. Echo reserves the right to update any unit returned for repair, and reserves the right to change or improve the design of the product at any time without notice.

This is your sole warranty. Echo does not authorize any third party, including any dealer or sales representative, to assume any liability on behalf of Echo or to make any warranty for Echo.

Service and repairs of Echo products are to be performed only at the factory (see below) unless otherwise authorized in advance by the Echo Service Department. Unauthorized service, repair or modification will void this warranty.

### To obtain factory service:

Contact Echo Corporation at (805) 684-4593, 9AM to 5PM Monday through Friday (Pacific Time). If necessary, you will be given a return authorization number. Products returned without an RA number will be refused. Echo may, at its option, require proof of the original date of purchase in the form of a dated copy of the original authorized dealer's invoice or sales receipt.

Pack the product in its original shipping carton and attach a description of the problem along with your name and a phone number where Echo can contact you if necessary. Ship the product insured and freight prepaid to:

**Echo Corporation  
6460 Via Real  
Carpinteria, CA 93013**

## DISCLAIMER AND LIMITATION OF WARRANTY

Echo Corporation makes no other warranties, express, implied, or otherwise, regarding Echo products, and specifically disclaims any warranty for merchantability or fitness for a particular purpose. The exclusion of implied warranties is not permitted in some states and the exclusions specified herein may not apply to you. This warranty provides you with specific legal rights. There may be other rights that you have which vary from state to state.

In no event will Echo Corporation be liable for any lost profits, or for any consequential, direct or indirect damages, however caused and on any theory of liability, arising from this warranty and sale.

©1999 by Echo Corporation  
6460 Via Real  
Carpinteria, CA 93013

Echo<sup>®</sup> is a registered trademark of Echo Corporation  
Layla<sup>®</sup>, Gina<sup>®</sup> and Darla<sup>®</sup> are trademarks of Echo Corporation  
Windows<sup>®</sup>, Windows '95<sup>®</sup>, Windows '98<sup>®</sup>, and Windows NT<sup>®</sup> are registered trademarks of Microsoft, Inc.

# **Table of Contents**

---

<b>Introduction</b>	7
What You Should Have Received in the Layla Box	7
System Requirements	7
<b>Layla Installation</b>	8
Running the Echo Reporter™ Software	8
The ECHODEL Program	12
System Sounds	13
Installing the Layla Hardware	14
Connecting to Layla's Rack-mount Interface	16
Installing the Layla Software Drivers	21
Layla Audio Input & Output Devices	24
<b>The Echo Console</b>	26
The File Menu	27
The Edit Menu	27
The Session Menu	28
The Monitors Menu	30
Console Controls	30
EasyTrim Automatic Gain Control	31
Monitor Controls	32
Output Controls	33
Adjusting Record and Playback Levels	34
Setting Clock Sources and Destinations	34
Synchronizing Multiple Devices	35
Console Keyboard and Mouse Shortcuts	37
Additional Configuration Settings	38
The Monitor During Playback Control	39
Selecting The S/PDIF Output Mode	39
SAW Compatibility Mode	40
Show Echo Console on the Taskbar	40
MIDI Time Code Settings	41
The Clocks Settings	43
<b>ASIO Driver Installation</b>	44

# **Table of Contents**

---

<b>Installing Cool Edit Pro™ — Special Edition</b>	45
Cool Edit Pro: Assigning Layla's Inputs & Outputs	46
Cool Edit Pro: Optimizing Multitrack Performance	47
<b>Contacting Customer Service</b>	49
<b>Appendix A: The Reporter Troubleshooting Guide</b>	50
<b>Appendix B: General Troubleshooting Guide</b>	52
<b>Appendix C: Resolving Interrupt Conflicts</b>	55
<b>Appendix D: Introduction to Digital Recording</b>	60
<b>Appendix E: Specifications</b>	64
<b>Index</b>	65

## **Introduction**

Thank you for choosing the Layla 20-bit Multitrack Digital Audio Recorder. We think you'll find Layla to be an extremely flexible, high-performance tool for your computer-based hard disk recording system.

## **What You Should Have Received in the Layla Box**

When you opened the Layla box, you should have found the following:

- A Layla PCI card wrapped in an anti-static cover
- A Layla rack-mount audio interface box
- A Layla digital control connector cable
- A compact disc containing the Layla Windows 95/Windows 98 Drivers, the Echo Reporter™ system analysis software, Syntrillium Software's Cool Edit Pro™— Special Edition multitrack recording and editing software, and demo versions of digital audio recording, editing, and processing software from a variety of manufacturers
- The Layla Owner's Manual
- Four adhesive backed rubber feet and four mounting screws with collars.

## **System Requirements**

In order to use Layla you'll need the following:

- An IBM-PC or compatible computer with PCI architecture expansion slots (version 2.1 PCI BIOS), a genuine Intel Pentium or faster CPU, a motherboard with an Intel chipset, and minimum 64Mb RAM (more highly recommended) running Windows 95 or Windows 98
- A fast, high-capacity IDE or SCSI hard disk drive
- Peripheral audio equipment, such as a mixer, power amplifier, DAT recorder, musical instruments, etc.

# Layla Installation

Complete Layla installation consists of performing a system check using the Echo Reporter™ software, installing the Layla PCI card, connecting the rack-mount audio interface to the card, installing the Layla Windows drivers into your system and, if necessary, installing a multitrack audio recording/editing application.

## Running the Echo Reporter Software

The Reporter is designed to provide you with an analysis of your computer system's audio capabilities and its ability to work successfully with Layla. The program looks at such things as your BIOS version, your interrupt assignments, and your hard disk's transfer rate. The Reporter will perform a limited series of compatibility tests. **It cannot guarantee that your system will work with Darla.** The only way to be sure is to install the card in your system and see if it works. Please note that we only support Intel CPUs and motherboards with an Intel chipset. Your system may or may not work with other CPUs or chipsets.

*Be sure to run the Reporter before attempting to install Layla* as it can help you avoid installation problems down the road. To run the Reporter, simply double-click on the **Install Reporter** icon in the **Reporter** directory of the Layla CD-ROM. This will install the program onto your hard disk. The Reporter will then show up under the **Start** menu, **Programs**, **Echo Audio Utilities**. Select The **Echo Reporter** to launch the program.

Once the program launches, you'll see the **Hard Disk Performance** test screen. Press the **Proceed** button to initiate the disk speed test. This test will tell you if your hard disk is fast enough to support multitrack digital audio and, if so, approximately how many tracks of record and playback you'll be able to achieve.



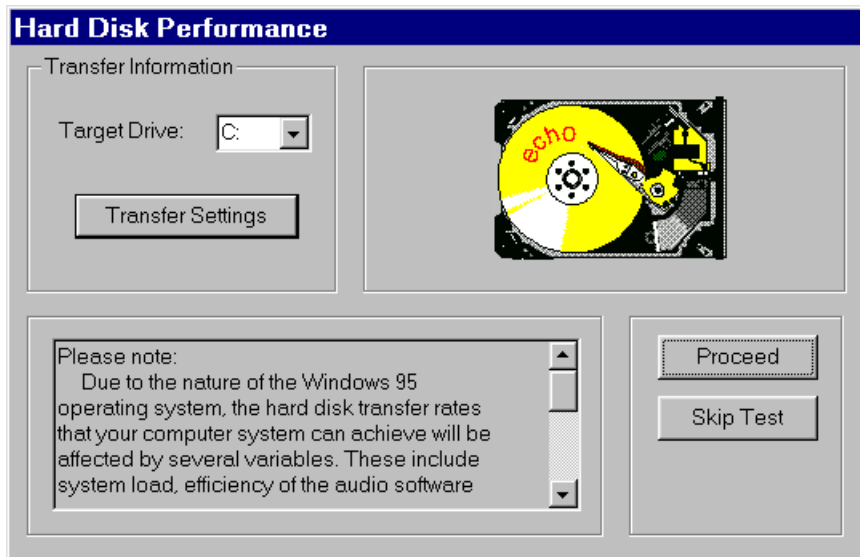

After the test is completed you'll see a results screen. Many of the parameters on the screen are interactive; you can change them to see how your disk performs under different conditions.

For example, in the upper right corner of the screen you can see how large your hard disk is and how many minutes of recording time it will provide for a mono track recorded at 44.1kHz with 16-bit resolution. (Times are expressed in Hours: Minutes: Seconds.) Change the **Number of Tracks** field to "2" and you'll see the maximum length available for a stereo track. Change the field to "8" and you'll see the maximum length you'll have for an eight-track opus. Naturally, these multitrack readouts presume uninterrupted, linear tracks. Your music is likely to contain numerous snippets of data (e.g., the background vocals will only appear at specific moments in time, not continuously throughout the whole tune), so, generally speaking, you'll be able to create longer pieces than the readout indicates.

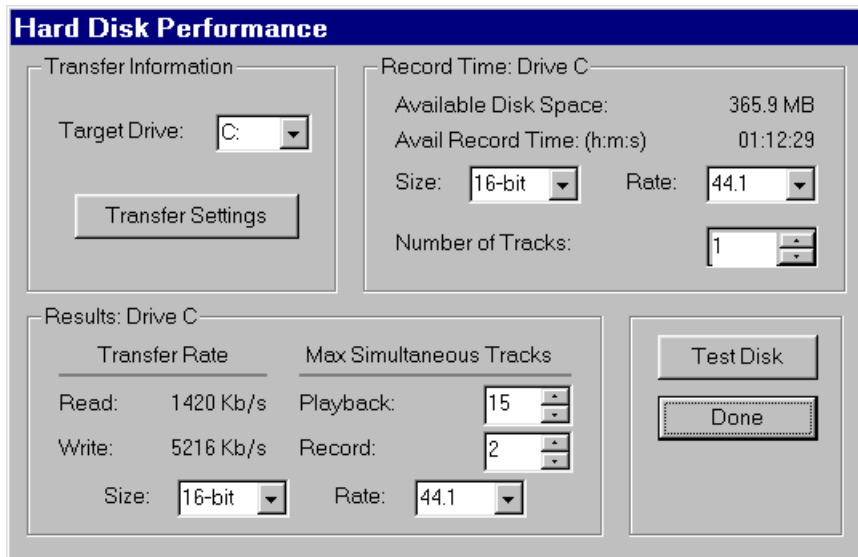

*You can adjust the parameters on the Hard Disk Performance screen to view your disk's record and playback capabilities at various sample rates and bit-resolutions.*

You can also change the **Size** (bit-resolution), **Rate** (sample rate), and **Number of Tracks** fields. Though the original test was performed with default values of 16-bit 44.1kHz, you can easily see your disk's performance reading and writing, say, 24-bit 48kHz data simply by selecting those values in the appropriate fields.

About the **Playback:** and **Record:** fields under the **Max Simultaneous Tracks** heading:

- At the basic level, these two fields show you how many simultaneous tracks of playback and recording your system will support. For example, if the readout was “15” for the **Playback:** field and “8” for the **Record:** field, that means your system is capable of playing back 15 tracks while simultaneously recording 8 tracks. Note, however, that the Playback: and Record: fields are interrelated: as you change the value in one field, the value in the other field is affected. In other words, the values are dynamic. You can get a feel for how much overall read/write bandwidth you have by adjusting the values in the two fields. By lowering the number of record tracks, you'll see the number of simultaneous playback tracks increase.

Similarly, by lowering the number of playback tracks, you'll see the number of record tracks increase.

- The readouts will generally show that you have fewer record tracks available than playback tracks. This is because writing data to a hard disk is a slower process than reading it back (due to the verify routines used when writing to disk).
- The values you see should not be taken as absolute. There are numerous conditions that come into play when determining overall performance, from operating system overhead to the audio application you're running (different programs use different file management schemes, with some more efficient than others). The readouts you get from the Reporter are meant to be taken as general guidelines. When you're actually running your audio software, you may get better results than the Reporter tells you—so don't run out and buy new hardware just because the Reporter tells you your system seems a bit on the weak side. Use your audio application in real-world conditions, then make the determination if your system can keep up with your needs.

(Conversely, if the Reporter tells you things look really bad, don't waste your time trying to do any serious work. If your hard disk is too slow or too small, you'll save yourself a lot of frustration by upgrading to a big fast disk right out of the chute—that is, unless you like random skipping and hiccups in your music. And don't skimp on RAM: we suggest a minimum of 64 MB, and load up from there. When it comes to multitrack digital audio, there's no such thing as too much RAM.)

When you're finished playing around with the disk test parameters, click **Done** to get to the Summary screen. There you'll see a complete analysis of the results of the tests, an explanation of those results, and recommended actions (if any are required). If the Reporter alerted you to any problems, you should check the appendixes at the back of the Layla Owner's Manual for help in isolating the cause of your difficulty and finding a solution.

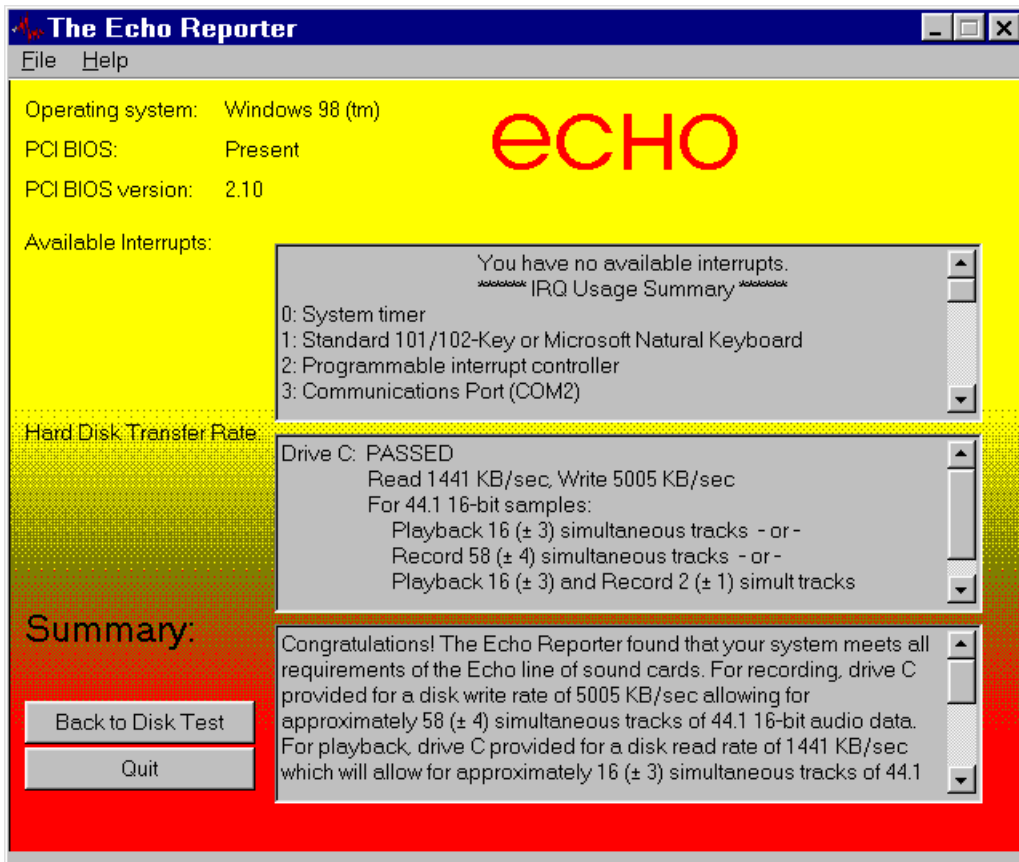

*The Summary screen tells you if your system can support multitrack audio recording as well as alerting you to potential problems.*

If your system passed the Echo Reporter test, it's time to move on to the next phase of installation.

## **The ECHODEL Program**

If you have previously installed an Echo audio card, such as a Gina, Darla, or Layla, it will be necessary to remove the old drivers before adding your Layla. If you are uncertain as to whether any of these cards have ever previously been installed in your computer, it might be wise to go ahead and perform the remainder of this step anyway. It will not harm any of your existing system files, and doing so will ensure that you are performing a "clean" installation. On the CD that accompanied your Layla is a program called ECHODEL.EXE. Simply run this program, following the program's instructions. It will make the appropriate deletions and update your Windows system files. (NOTE: It is necessary to run the ECHODEL

program anytime you add an Echo audio card to your system, even if you are merely exchanging one card for an identical one (such as during a warranty exchange). Be sure to restart Windows after you run the ECHODEL program.

## **System Sounds**

There is one final step to perform before installing the Layla hardware. We suggest that you turn off your Windows system sounds prior to installing Layla. Because most system sounds are sampled at very low sample rates, typically 8 to 11 KHz, each time they are played it will cause the sample rate clock on Layla to reset to the slower speed

To turn off the system sounds, first go to the Windows **Control Panel**, which can be found under **Settings** from the **Start** button. On the control panel you will find an icon titled “**Sounds**”. After double clicking on this icon, you will see a window labeled “**Schemes**” near the bottom of the screen. Click on the small down arrow to the right of the combo-box and select the “**No Sounds**” option. Then click on the Ok button.

## **Installing the Layla Hardware**

Once you have run the Reporter software, have verified that there are no problems with your system, and have removed any old driver software with the ECHODEL program, it is time to install Layla into your computer.

***IMPORTANT - Unplug your computer and detach all peripherals before proceeding with the following steps.***

1. Remove your computer's cover. This operation differs from computer to computer. Refer to your computer's manual for a further explanation of this step if necessary.
2. Select the slot into which you will install the Layla card. The Layla card is PCI architecture. Inside your computer you will likely find two types of expansion slots, ISA and PCI. The PCI slots will be shorter and have a higher connector pin density than the ISA slots. You may use any of the available PCI slots in your computer for Layla. Unscrew and remove the bracket covering the expansion slot where you would like to install Layla. Put the screw in a safe place, as you will need it later to complete the installation.
3. Insure that you have fully discharged all static electricity from your body before handling the Layla card. This can be done through the use of a grounding strap or, more simply, by touching your bare hand to the metal casing of the computer's power supply. (For this latter method to work, the computer must be plugged in, though not turned on. After you've discharged your static, unplug the computer before proceeding to the next step.)
4. Remove the Layla card from its protective anti-static bag. Handle the card carefully by its edges and insert it into the selected expansion slot. Insure that the card's edge connector (the protruding edge with the gold leads) is seated firmly into the slot. Centering the card over the slot and using a gentle rocking motion while pushing downward into the slot generally works well. Be careful not to force the card into the slot, or bend or twist it while it is being inserted, as this could result in the card being damaged.

5. Use the screw removed earlier from the protective backplate to attach the metal bracket at the back of the Layla card to the computer's rear panel.
6. Replace the computer's cover and secure it. Reattach its power supply cord and reconnect any peripherals that you may have removed prior to beginning the Layla installation.
7. Locate the Layla rack-mount interface and the 25-pin audio connector cable. Securely mount the interface into your equipment rack. If you will not be mounting the box in a rack, remove the backing from the four rubber feet and place one in each bottom corner of the interface unit. Then be sure to locate the rack-mount box in a secure location.

Plug one end of the cable into the 25-pin connector on the Layla card that now protrudes through the back panel of your computer, and secure the cable using the built-in screws located on both sides of the connector. Attach the other end of the cable to the rear of the interface and fasten the cable securely with the screws.

***Caution: Never connect the rack-mount interface to the computer while either the interface or your computer is turned on.***

8. You can now attach external audio devices to the rack-mount box. Layla can accommodate eight analog input signals and can generate ten independent analog output signals. In addition, Layla provides word clock/superclock sync, MIDI in/out/through, and stereo S/PDIF digital input and output. Additional information on attaching external devices to Layla may be found in the **Connecting to Layla's Rack-mount Interface** section. (NOTE: When connecting devices to the S/PDIF jacks on Layla, do not use standard RCA audio cables. For reliable S/PDIF operation, 75ohm coaxial video cables are recommended).

All of the analog and digital inputs and outputs on Layla are simultaneously active, allowing you to record up to 10 channels of audio (eight analog and two digital) while playing back twelve channels (ten analog and two digital).

## Connecting to Layla’s Rack-mount Interface

The back panel of Layla’s rack-mount interface contains a wide variety of connections that allow great flexibility in the operation of Layla. To achieve the optimal performance with Layla, it is critical that the appropriate cabling and connectors are used.

### Analog Inputs and Outputs

Layla has eight analog inputs and ten analog outputs on the back panel, as well as two inputs on the front (the two inputs on the front are alternate connectors for channels 7 and 8 on the back of Layla. When you plug into the front panel inputs, the corresponding back panel inputs are disabled). These connections can accept balanced or unbalanced signals.

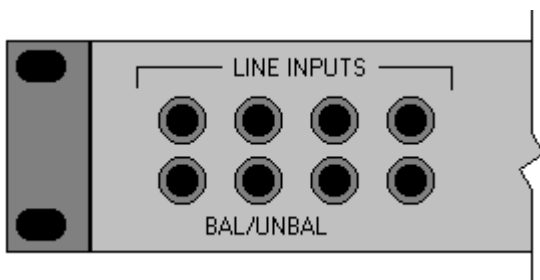

An unbalanced signal contains two components, a ground signal and a “hot” or active signal. A balanced signal contains these two components with the addition of a second active channel that is 180 degrees out of phase from the primary signal. In this way, a balanced signal can eliminate any noise that may be introduced into the audio signal during transmission. The connectors used for the analog inputs and outputs on Layla are TRS (tip, ring sleeve).

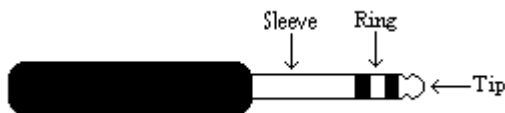

The three sections of a TRS connector are used to transmit the three components of a balanced signal. Layla will also accommodate the two conductor unbalanced style connector.



## The Host Connector

Next to the analog inputs and outputs is a connector labeled **HOST**. This connector is known as a DB-25, and is commonly used on PCs for the printer port. It is the point at which the audio interface connects to the Layla PCI card inside your computer.

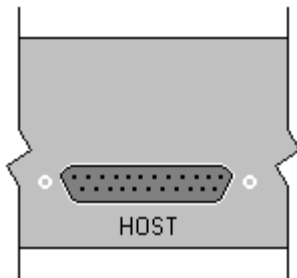

A cable was supplied with your Layla for this purpose. This cable is manufactured to certain specifications, and if necessary, should only be replaced with a cable that meets specification IEEE-1284. Layla is designed for use with cables of up to 15 feet in length. Cables in excess of 15 feet may cause loss of data and/or diminished system performance.

## S/PDIF

Next to the **Host** connector is a pair of connectors labeled **S/PDIF in** and **out**. S/PDIF is used to transmit digital data among digital audio devices. S/PDIF data can use the full 24-bit sample width used internally on Layla.

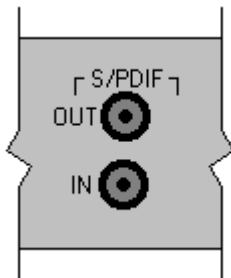

When connecting devices to the S/PDIF jacks on Layla, the use of standard RCA audio cables is not recommended. For reliable S/PDIF operation, 75ohm coaxial (RG59) video cables are recommended.

## Word Clock

Next to the S/PDIF ports are the **Word Clock** connectors. These connectors allow you to synchronize one Layla to another Layla or to other digital audio devices. In addition to a standard word clock signal, these connectors also allow you to synchronize using the superclock format, which is 256x the selected sample rate.

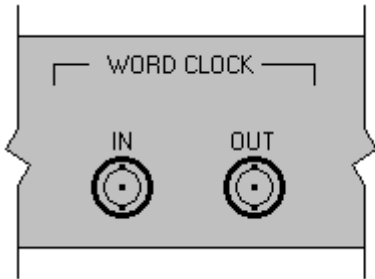

The word clock I/O uses a BNC connector. As with the S/PDIF I/O, a shielded 75 ohm (RG-59) coaxial video cable should be used. BNC connectors are widely used in the electronics industry for both video and computer networking. However computer networks use 50 ohm (RG-58) coaxial cables and not the 75 ohm (RG-59) cable used by video. For reliable word clock operation, use only video cables with Layla.

## MIDI

The last set of connections to the Layla interface is for MIDI. The MIDI ports can be used for receiving MIDI time code (MTC), sending MIDI signals from your digital audio/MIDI sequencing software to external sound modules, etc.

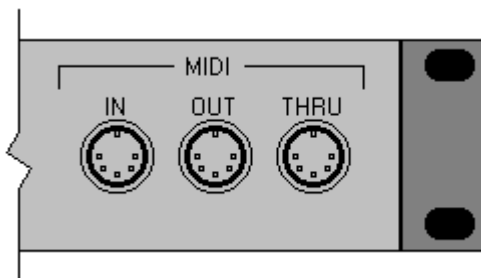

MIDI cabling is highly standardized and widely available.

The diagrams on the following two pages illustrate sample configurations using Layla and external audio equipment:

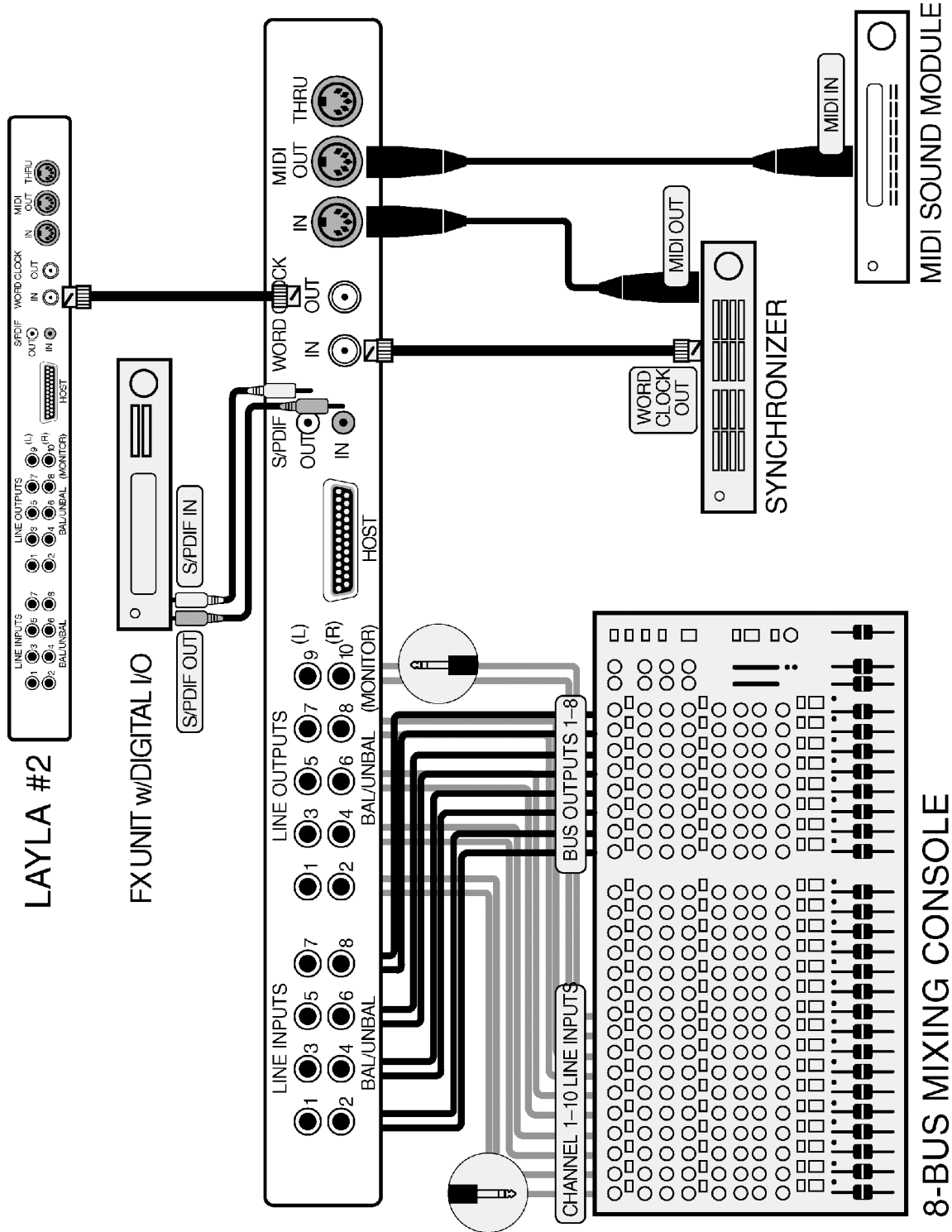

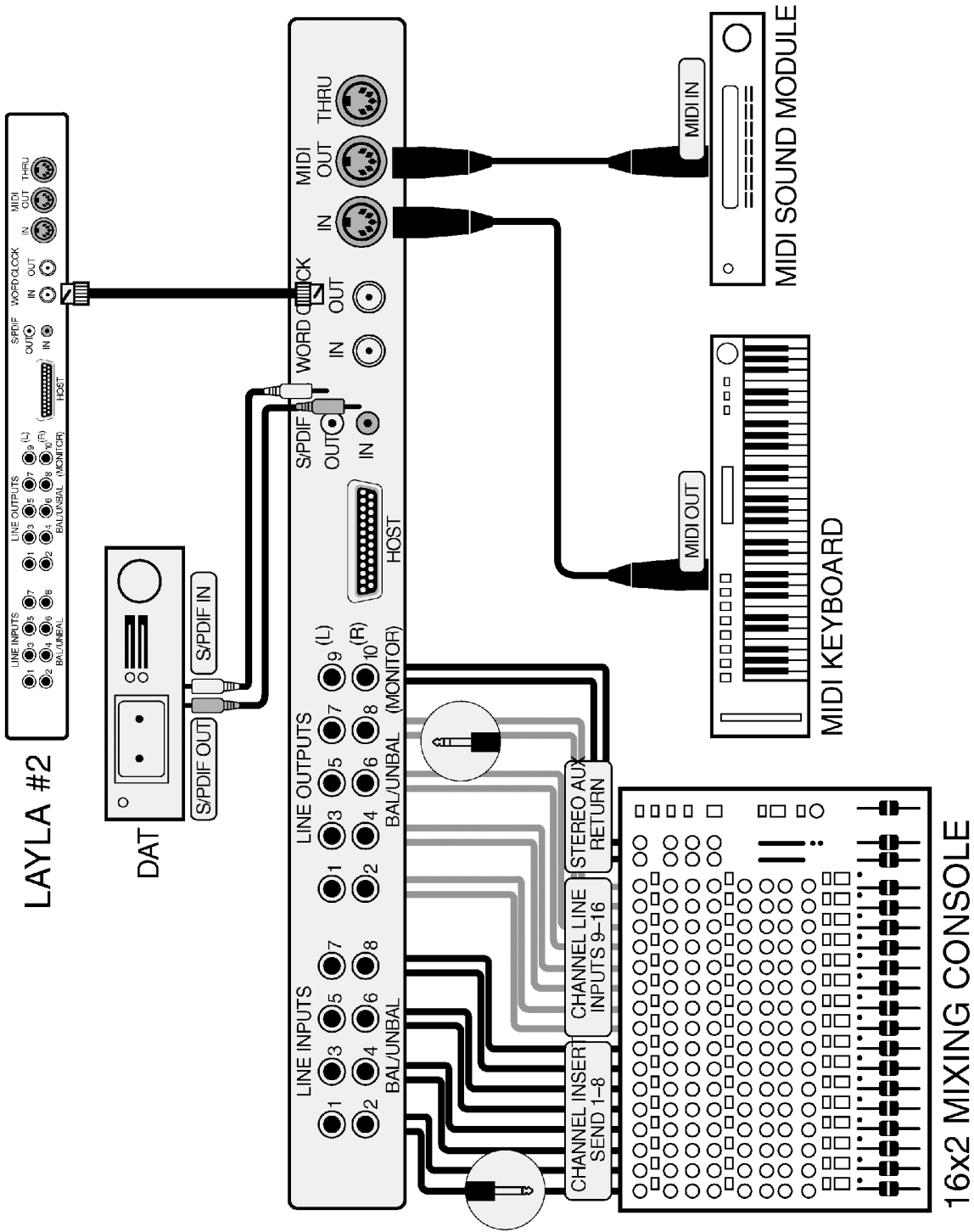

## Installing the Layla Software Drivers

Now that you have completed the hardware installation, you need to install the software drivers that allow Layla to interact properly with Windows 95/98 and your audio recording application.

Turn on the power to your computer's CPU. After Windows 95/98 starts up, it will automatically sense the newly installed Layla card and indicate, via a pop-up Install Wizard window, that new hardware has been found. At this point, you should insert the Layla CD-ROM disc.

If you are using the original Windows 95:

Within the Install Wizard window are several options. Select the option **Driver from disk provided by hardware manufacturer**. The computer will now prompt you for the location of the driver files. These files are located in the root directory of the Layla CD-ROM. Click the **Browse** button in the Install Wizard; this will cause the **"Install From Disk"** window to appear. In the field labeled **"Copy manufacturer's files from:"**, enter the path **D:\** (depending on your system configuration, your CD-ROM drive may use a letter other than "D"). Click on **OK** to complete the installation. Now turn to page 22.

If you are using Windows 95 OSR2:

After you have inserted the Layla CD-ROM disc and clicked **next**, you'll see the message, "Windows found the following updated driver for this device, Layla by Echo." Click on the **Finish** button and Windows will attempt to locate the drivers on a disk labeled "Echo Install Disk." Unfortunately, no such disk exists. So what you'll see is a not-so-nice error message marked with a big red X. Ignore Windows' rude behavior and click on the OK button. This will bring you to the **Copying Files . . .** window. Within the window is a field labeled **Copy Files From:** into which you'll need to enter the path name for the Layla drivers. Type in the letter name of your CD-ROM drive followed by **:\** (for example, **D:\**). Click on **OK**, and Windows will complete the driver installation routine. Now turn to page 22.

If you are using Windows 98:

After you have inserted the Layla CD-ROM disc and clicked **next**, you'll see the message, "What do you want Windows to do?" Below that are two radio buttons. If it isn't already selected, select the one labeled "Search for the best driver for your device (Recommended)". Click on the **Next** button and a dialog will appear with several check boxes indicating places where Windows will look. If you are installing from a CD-ROM drive or from a floppy disk, click on the appropriate box. Be sure all others are unchecked. Click on the **Next** button and Windows will locate the drivers on the install disk and show you the **Copying Files . . .** window as it completes the driver installation.

After the drivers are installed, you should verify that Windows recognizes them. You can do this by checking in the Windows Control Panel as follows:

Begin by clicking on the Windows **Start** button. Then select **Settings**, followed by **Control Panel**. Now double-click on the icon labeled **System**. At the top of the **System** window, you will see a tab labeled **Device Manager**; click on the tab. Now locate the line labeled **Sound, Video, and Game Controllers**. Double-clicking on the “+” to the left of the line’s associated icon should reveal the line **Layla by Echo**; double-click on that line. The “Holy Grail” that we’re searching for is a message that, if everything is in working order, should now appear on your screen. In the center of the Layla Properties window will be a section called “Device Status.” Look for a message that reads “This device is working properly.” If you see it, give yourself a hearty pat on the back for a job well done!

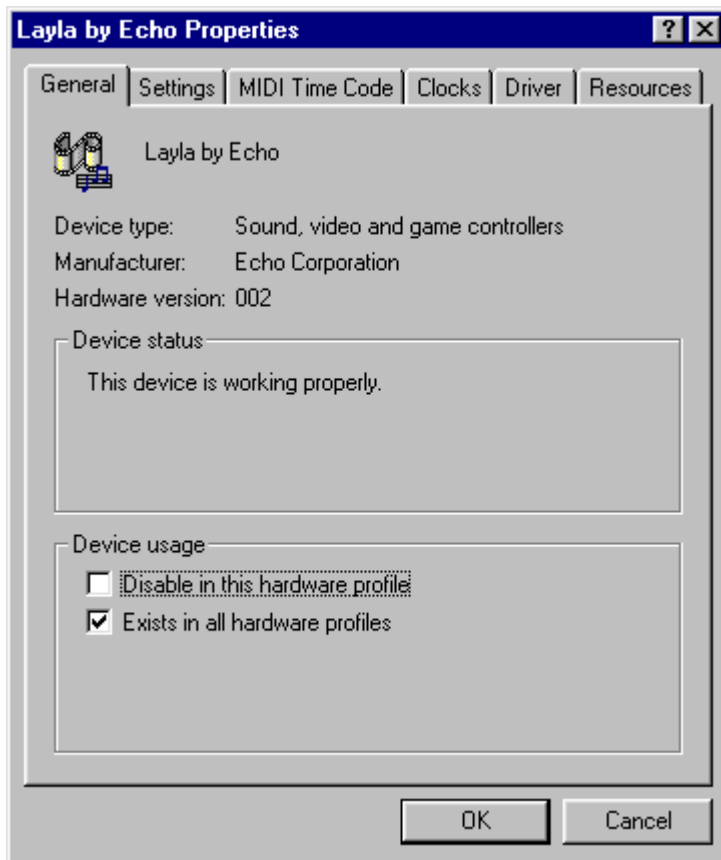

*Proper installation of the Layla drivers will result in the message, “The device is working properly.”*

If the message does not appear, check Appendices A, B and C for help in isolating the cause of your difficulties.

You can now exit back to the **Control Panel** window to check the Layla audio input and output devices that are available. In the **Control Panel** window, locate the **Multimedia** icon and double-click on it. This will bring the multimedia **Properties** window into view. Select the **Audio** tab to see a list of available playback and recording devices in the **Preferred Device** fields.

## **Layla Audio Input & Output Devices**

The Layla driver installs into your computer as a series of stereo .WAV devices. Pulling down the **Preferred Device** menu in the **Control Panels/Multimedia/Audio Playback** section will reveal the available Layla devices. You will be able to select from:

- Layla 1/2 Analog Playback
- Layla 3/4 Analog Playback
- Layla 5/6 Analog Playback
- Layla 7/8 Analog Playback
- Layla 9/10 Analog Playback
- Layla S/PDIF Playback

In the **Recording** section, the following choices will be available:

- Layla 1/2 Analog Record
- Layla 3/4 Analog Record
- Layla 5/6 Analog Record
- Layla 7/8 Analog Record
- Layla S/PDIF Record



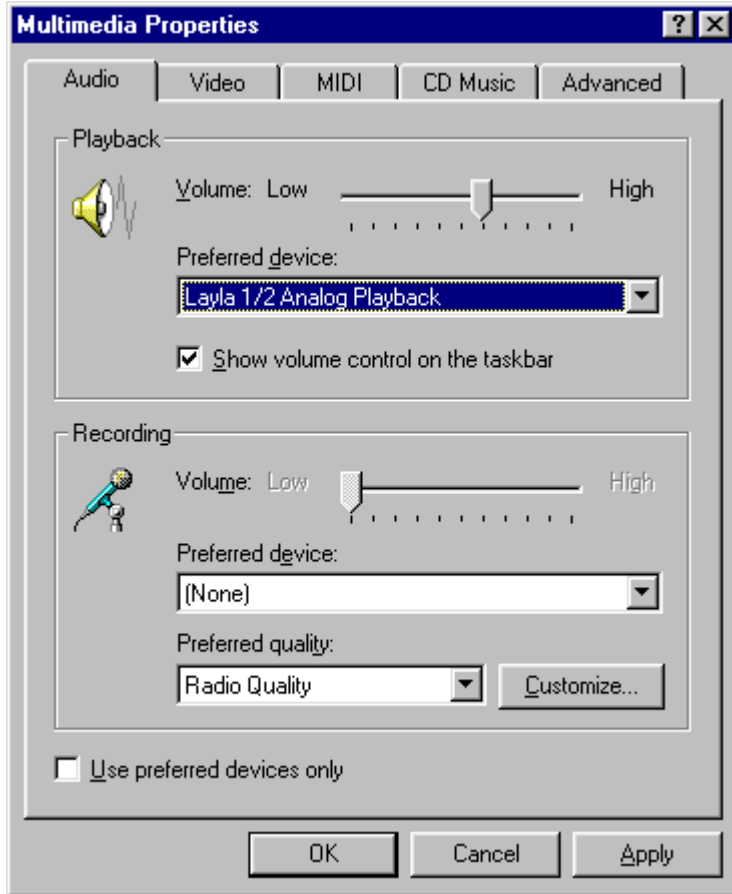

*You can view the Layla input and output devices in the Multimedia Properties/Audio window.*

You'll find these same input and output options available when using your audio record/editing software, with the devices assignable on a per-track basis. See your software owner's manual for details on how to make these device assignments. Instructions for making these assignments in Cool Edit Pro™— Special Edition can be found on page 44 of this manual.

This completes the installation of the Layla hardware and software.

# The Echo Console

Included with your Layla is a “virtual control surface” application called The Echo Console. The Console allows you to control the audio I/O and clocking functions of Layla, and it brings these controls to a single easy-to-use location. From the console you can control input and output levels, select synchronization clocks, adjust input monitoring, and activate the EasyTrim™ automatic input gain adjustment circuitry.

The Echo Console software was automatically installed at the same time that you installed the Layla drivers for Windows 95/98. If installation was successful, you should see a capital letter L in your Windows ‘95/98 taskbar (typically in the bottom right-hand corner of your screen). Clicking on the “L” will activate the console program. It should look like this:

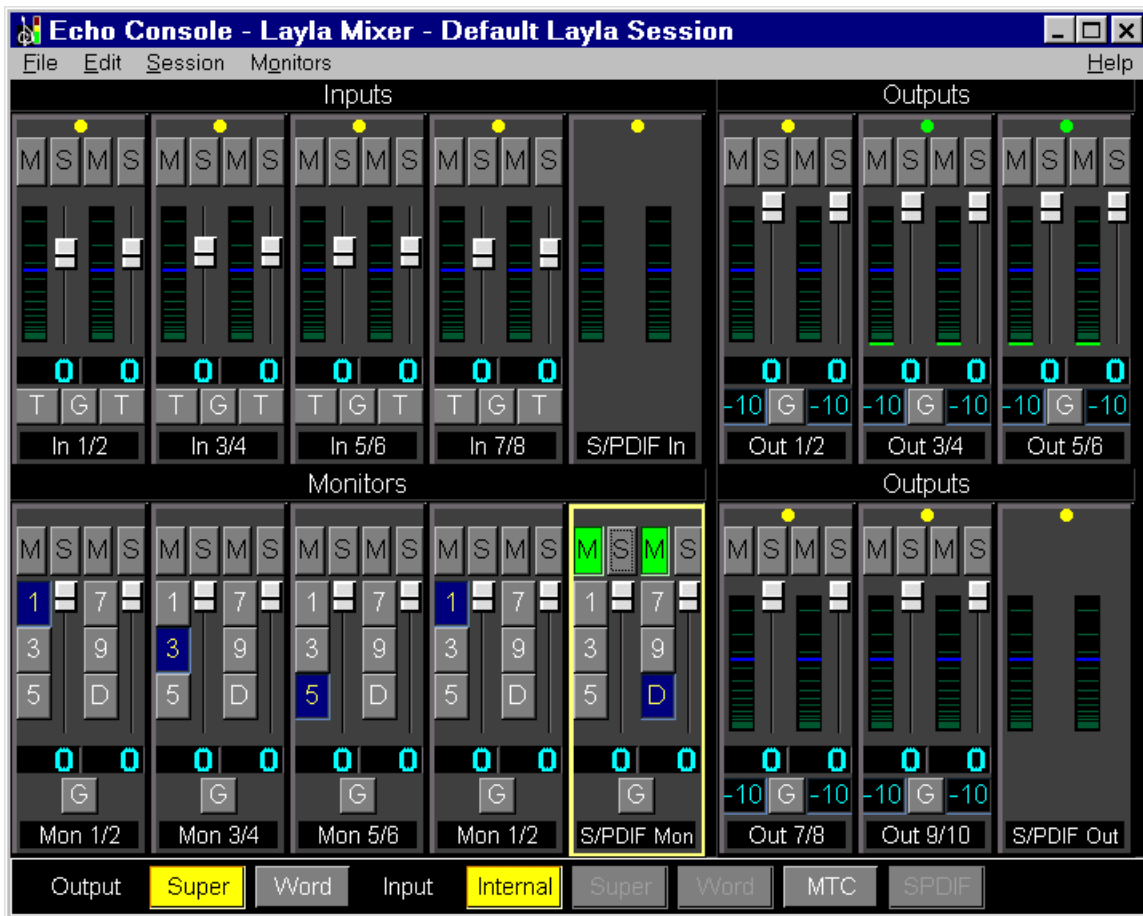

The console functions are grouped into three areas: inputs (in the upper left corner), monitors (directly below the inputs that are being monitored), and outputs (on the right hand side). The controls for a particular function/stereo pair are then further grouped into a box that contains selection buttons, a slider, and other controls and displays as determined by the function.

## **The File Menu**

At the top left of the Console window you will find the **File** menu. By selecting the File menu, several configuration options become available to you. The first menu option is “**New Console**”. The **New Console** option allows you to create an additional iteration of the console program. In this way, multiple devices (Laylas, Ginas or Darlas) may be controlled using their own dedicated console.

The second option under the File menu is “**Exit**” which closes the current instance of the console.

## **The Edit Menu**

The “**Appearance**” option, first on the Edit menu, lets you customize the look of your console. You can change the color of each of the console elements, change the fonts used, or choose to abbreviate labels. You may even want to produce multiple color schemes to help recognize the device that is being controlled. A number of preset color schemes are included.

The second option on the Edit menu is “**Input Levels.**” This option produces the following window:

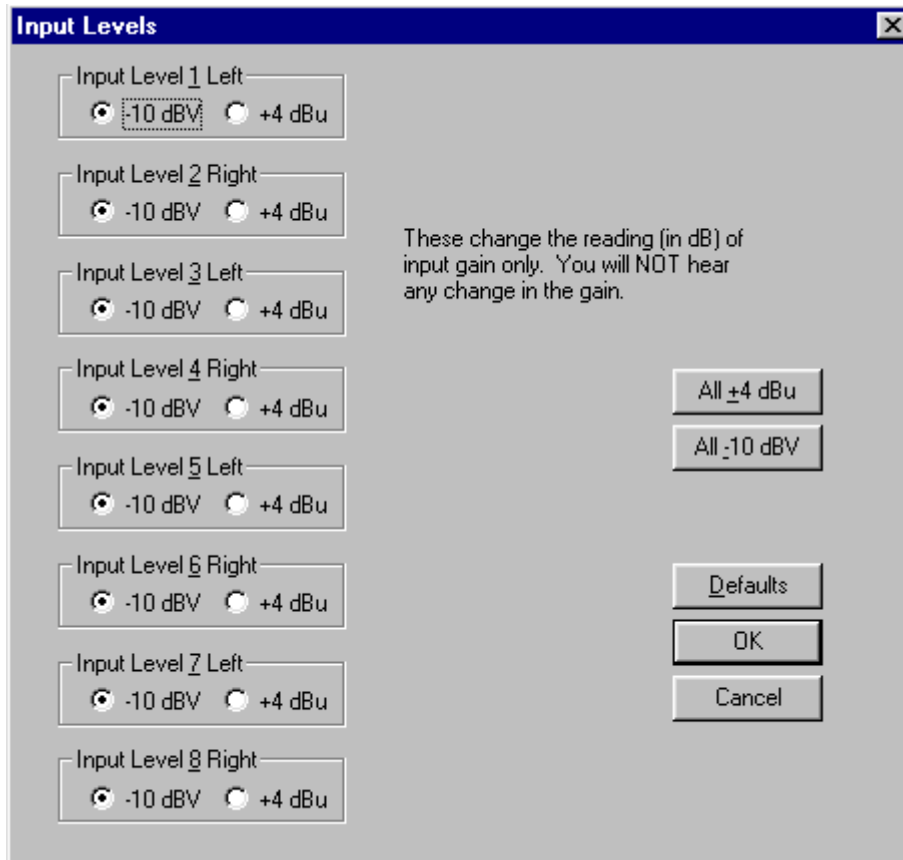

The **Input Levels** window lets you choose the gain level for each of the analog inputs on Layla. In this way devices with differing nominal operating levels are easily accommodated, and their input gain levels properly displayed on the Echo Console.

The third option under the Edit menu is “**Mixer Device.**” The **Mixer Device** option lets you choose the device that the current iteration of the Console program controls. So, if you have more than one device (Layla, Gina or Darla) attached to your system, you can use the same console to control them all using the **Mixer Device** option to control which device is currently selected.

## The Session Menu

Users now have the ability to save and restore any number of different console states. A console state contains the state of each user-selectable console setting excluding color scheme and font.

The “**Open**” option, first on the Session menu, lets you open a previously saved session.

The “**Save**” option, second on the Session menu, lets you save any changes made to the current session.

The “**Save As..**” option, third on the Session menu, lets you save any changes made to the current session under a different name.

The “**Delete..**” option, fourth on the Session menu, lets you delete any session.

The “**Select Default Settings**” option, fifth on the Session menu, lets you change to default session settings. This is not the same as opening the default session! Rather it is a set of pre-defined settings.

The “**Auto Save Default Session**” option, sixth on the Session menu, automatically saves any changes made to the default session whenever the console is closed or a new session opened without prompting the user with:

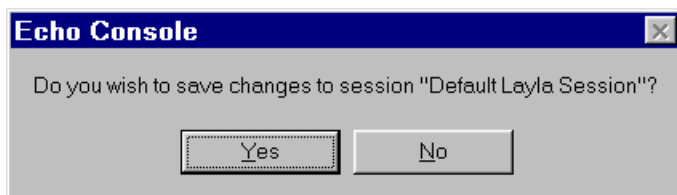

This option insures that any changes you make to the default session will never be lost. When a check appears on this menu item, the feature is enabled.

The last option on the Session menu is a list of the last sessions opened. You can quickly open a previous session by simply clicking on its name in the list. For those who like using the keyboard, pressing the corresponding number (displayed with an underline before the session name) also works.

## The Monitors Menu

The “**Group Mode**” option, first on the Monitors menu, lets you toggle group mode on and off. See the **Monitor Controls** section below for a description of how this feature works.

The “**In-Line**” option, second on the Monitors menu, cascades the monitors so there is a one to one correspondence between input and output channels. In other words, input channel 1/2 is monitored by output channel 1/2, input channel 3/4 is monitored by output channel 3/4, etc. See the **Monitor Controls** section below for a complete description of how the monitor feature works.

## Console Controls

Let’s take a look at the control surface. The input controls are located in the upper left portion of the console surface. In the center of each input control is a pair of sliders for input gain attenuation. You will also find a pair of level meters. Below each meter/slider pair is a display that shows the currently selected level of attenuation or gain. One note about this display: You will notice that the colors used to draw the gain display vary depending on the input levels that are selected from the **Input Levels** selection window from the **Edit** menu.

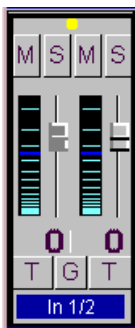

Above the meters are buttons that allow you to selectively mute (M) or solo (S) each channel. The “LED” at the top of each input control is a button as well. It is used to enable (green) or disable (yellow) the level meter for this channel pair. At the bottom of the control you may choose to “gang” the sliders (G). Ganging the sliders ties them together so that they will maintain

their relative placement with regard to each other. You can also activate the EasyTrim function (T).

## **EasyTrim™ Automatic Input Gain Adjustment Circuitry**

EasyTrim is a feature that monitors the peak level of the input signal and automatically adjusts the input gain for maximum performance, i.e., the point that offers the greatest signal-to-noise ratio for the material being recorded. This allows you to take full advantage of Layla's 20-bit dynamic range, as it eliminates the need to leave a few dB of extra headroom, "just in case", while recording.

To enable EasyTrim, simply push the desired input channel's EasyTrim button (labeled "T" on the console). Now begin playing the material you plan to record. In order for the EasyTrim function to work properly, it is important that you play the loudest material you will be recording on that channel. EasyTrim is going to optimize the input level based on the loudest signal detected during this monitoring process. If you exceed that level during the actual recording process, you could introduce clipping distortion.

**Note that while you have EasyTrim enabled, the volume level for the enabled channel(s) is significantly reduced. This is a normal function of EasyTrim, allowing this feature enough headroom to accommodate a wide variety of input levels. When EasyTrim is deactivated, the volume level(s) will return to normal.**

Once you have played the loudest passage, deselect the EasyTrim button to exit the EasyTrim mode—the slider will jump to the correct input gain position. Layla is now set to provide the widest possible dynamic range for the material you will be recording. It is recommended that you repeat the EasyTrim level-setting process for each successive track you plan on recording. That way you can always be assured of getting the maximum dynamic range out of your Layla system.

## Monitor Controls

Below the input channels are the input monitor controls. The input monitor controls allow you to monitor the record input signal via any of the available outputs on your Layla. Each input channel pair has a corresponding monitor output pair directly below it on the console. The monitor controls look similar to the controls for input. The same mute and solo buttons are found at the top, and the gang selection button is at the bottom. In addition, a pair of slider controls is available for setting the levels of the monitor signals. Instead of level meters, the monitor control has a series of numbered buttons. These buttons allow you to select which output channel pair controls are displayed, so you can adjust them.

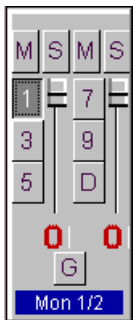

The monitors are one of the most powerful functions of the console. When you are recording, these controls allow you to set the level at which each input signal will be monitored at each of the outputs, independent of the main output level control.

When setting a monitor level, you must first select the input that will be monitored, and then select the output for which you will set the monitor level. Selection of the input is really just a matter of using the correct monitor control box. A monitor setting will always affect the input pair that is directly above it. To set the monitor for inputs 3/4, for example, simply go to the monitor control directly below inputs 3/4 and click on one of the six buttons found in the center of the control.

Let's say you want to set the level at which input pair 1/2 is monitored for each of the five stereo analog output pairs on Layla. You would first find the monitor control that corresponds to inputs 1/2 (the control on the far left, directly below the input control for channels 1/2). Clicking on the button



within this box labeled “1/2” causes the control box to display the currently selected levels at which inputs 1/2 are being monitored at outputs 1/2. Clicking on the button labeled “3/4” would cause the control box to display the currently selected levels at which inputs 1/2 were being monitored at outputs 3/4. You can move through the remaining buttons, setting the level at which inputs 1/2 are monitored at each of the six output pairs. The console program remembers any settings that you make, and all settings for all outputs are maintained independently.

In the “**Monitors - Group Mode**” menu, you can select the group mode function which lets you easily move through the output pairs on Layla, building the monitor mix that you want for each output. Let’s say you have five musicians, each one listening to their own discrete output pair. Clicking “Group Mode,” then clicking on output button “1/2” on any of the monitor panels would cause all of the monitor controls to become active for outputs 1/2. You could make adjustments for each input pair as necessary. Clicking on “3/4” in any of the panels would then switch all of the monitor controls to the levels for output pair 3/4, so you could set the levels for the next musician, and so on.

Remember that all of the inputs are continuously monitored by all of the outputs at some level. The degree of attenuation (or muting) of that level is set by the monitor controls. The console program constantly maintains a level setting for each of the 60 monitor paths it controls. Clicking on an output selection button simply selects the settings that are displayed.

## **Output Controls**

The right hand side of the console is dedicated to the controls for output channels one through ten (an output meter is included for the two S/PDIF output channels, but these levels are not adjustable). Here again, the available controls mirror those found on the input controls: (Gang, Mute, Solo, meter on/off, etc.)

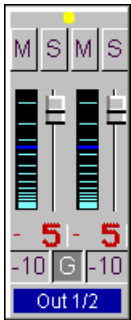

Where the EasyTrim buttons are located on the input controls, you will instead find buttons that allow you to select each channel's output level (much as you can set input levels from the File menu option described above). These buttons toggle Layla's outputs between +4dBu and -10dBV levels. These toggles should be set to the level that is appropriate for the devices that are being connected to the Layla output channels.

## Adjusting Record and Playback Levels

Layla's output volume adjustments are made in the digital domain. When you lower a volume slider, you are actually decreasing the number of available bits, thereby taking away from the potential dynamic range of the system. To avoid this, we suggest that whenever possible you leave the output sliders set to their maximum positions, and perform any necessary attenuation on your external mixer. When the Layla playback volume controls are set to maximum and the input signal approaches the maximum pre-clipping level, you can achieve the full 20-bit dynamic range of the system.

## Setting Clock Sources and Destinations

At the very bottom of the Console there are buttons that allow you to select the synchronization clocks that are used by Layla. The console program will sense which input clocking options are available, and automatically disable those that are unavailable. On the left are the output clock options.

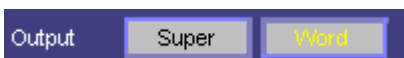

Here you can select from standard word clock or super clock (word clock x 256) output. To the right of the output clock selections are the input clock

options. Depending on what external devices you have connected to Layla, you may have as many as five options here.



If you are unsure which clock synchronization selections are appropriate for your installation, be sure to read the next section, which deals with the types of clocks that Layla supports.

## Synchronizing Multiple Devices

Layla is designed to work alongside other audio equipment within a complete Windows system. If you are planning on using Layla with other audio equipment, please note the following:

The Layla Windows drivers (echogals.driv and echogals.inf) included in this package supports multiple Laylas within the same system. In addition, your new Layla will operate with Gina and Darla. Layla can also peacefully coexist with audio equipment from other manufacturers, but be aware that operating *alongside* another product is not the same as operating *with* it. In order for accurate synchronization to occur, the other audio product(s) in your system must support a synchronization mode (word clock, super clock, etc.) that is compatible with Layla. Without such synchronization, the individual pieces of equipment will act independently of each other. This scenario may be fine for some musical applications; however, it is not appropriate for situations where sample-accurate synchronization is required.

For this reason, Layla supports many synchronization modes. Layla can slave to word clock, super clock, S/PDIF, and MIDI Time Code (MTC). In addition, Layla can also generate these synchronization signals, as well as perform translation of one clock to another, such as transmitting super clock while reading MTC.

Let's take a brief look at the various synchronization types.

**Word Clock** – This is a synchronization signal that connects to the BNC connector labeled **Word Clock** on Layla's back panel. This synchronization clock runs at the selected sample rate. Think of it as a kind of electronic

metronome, which can click back and forth at speeds surpassing 48,000 times a second. It is one of the most widely used forms of synchronization in digital audio.

**Super clock** – This signal comes from Layla’s **Word Clock** connector too. Its signal runs at 256 times the sample rate. A lot of equipment, including Layla, uses a 256x word clock internally. Using super clock allows the equipment to synchronize more accurately and adjust more rapidly to different sample rates.

**Note:** A lot of equipment, including many “clock synchronizers”, generate super clock using a “phase lock loop” or PLL circuit. This can produce a super clock with a lot of “jitter,” which can cause noise on Layla’s (and other) analog converters. Layla has a “low-jitter” clock generated using digital synthesis techniques. It is recommended that word clock be used when slaving Layla to other external equipment, reserving super clock for synchronizing multiple Laylas together.

**S/PDIF** – The Sony/Phillips Digital Interchange Format is a serial bit-stream that has a clock signal embedded in the data stream. When recording from a S/PDIF source, Layla will utilize the synchronization clock that is embedded in the S/PDIF while it decodes the bitstream.

**Note:** When recording from an S/PDIF port, you must select S/PDIF as the input clock. For greater flexibility, this is not done automatically. If you find that your S/PDIF recordings contain pops or skips, be sure that you have selected S/PDIF as your input clock.

**MIDI Time Code (MTC)** – MIDI time code differs from the preceding synchronization methods. Instead of simply providing the rate at which things should proceed, it transfers information in an elapsed time format (HH:MM:SS.) In addition, MTC also transmits a frame number to give the fine definition that is needed. This longitudinal format has the benefit of including positional information; however, over time it tends not to maintain as tight a sync as sample based synchronization techniques.

Now let’s take a look at some possible configurations and how you might set them up from a synchronization standpoint.

Let's start simple. Suppose that Layla is the only audio device used in your system. Since you have no other devices to synchronize with, simply select "Internal" for Layla's input clock. Layla will then use its own clock to control its operation.

Now a little more complicated set-up: You have two Laylas connected. Simply set Layla #1 to "Internal" for its input clock and super clock for output. Now connect the first Layla to the second one via a BNC cable running from Word Clock Out on Layla #1 to Word Clock In on Layla #2. Now select super clock for Layla #2's input synch. Your Laylas will now operate in unison.

No matter how many devices you are synchronizing, the concept is essentially the same. You are merely "daisy-chaining" devices together using compatible clocks. One device will operate as the source of the master clock, with each successive device using that clock to sync.

## Console Keyboard and Mouse Shortcuts

To navigate between control groups:

- Ctrl + Tab** Move to next control group.
- Ctrl + Shift + Tab** Move to previous control group.

To navigate between controls within a control group:

- Tab** Move to next control.
- Shift + Tab** Move to previous control.
- Ctrl + S** Toggles between left & right Solo buttons.
- Ctrl + M** Toggles between left & right Mute buttons.
- Ctrl + A** Toggles between left & right Trim buttons.
- Ctrl + T** Toggles between left & right +10/-4 buttons.
- Ctrl + G** Select the Gang button.
- Enter** Toggles the state of any selected control.

To control volume sliders:

- Right mouse click** Allows user to type in the desired level.
- Ctrl + left mouse click** Set volume level to zero.
- Ctrl + ↑** Raise volume of selected control about 5 dB.
- ↑** Raise volume of selected control about 1 dB.

<b>Ctrl + Alt + ↑</b>	Raise volume of selected control about 0.004 dB.
<b>Ctrl + ↓</b>	Lower volume of selected control about 5 dB.
<b>↓</b>	Lower volume of selected control about 1 dB.
<b>Ctrl + Alt + ↓</b>	Lower volume of selected control about 0.004 dB.

Individual channel titles are customizable. To change the text of a channel title (i.e., In 1/2, Mon 3/4, Out 5/6, etc.), **right mouse click** on the channel title and type in the desired text.

## **Additional Configuration Settings**

In addition to those settings that can be made using the Console program, there are a number of other configuration options you can access. These are found on the Windows Control Panel. To access these controls, begin by pressing the Windows **Start** button. Select **Settings**, then **Control Panel**. In the Control Panel window, locate the icon for **System**, and double-click on it. Click on the tab titled **Device Manager**. Now locate the line titled **Sound, video and game controllers**. Finally, locate the line titled **Layla by Echo**, and double-click. This will bring up the Layla Properties window, which we saw briefly at the conclusion of Layla installation.

We have previously seen the “General” screen, so let’s move on to the “Settings” screen by clicking on the tab labeled **Settings**.

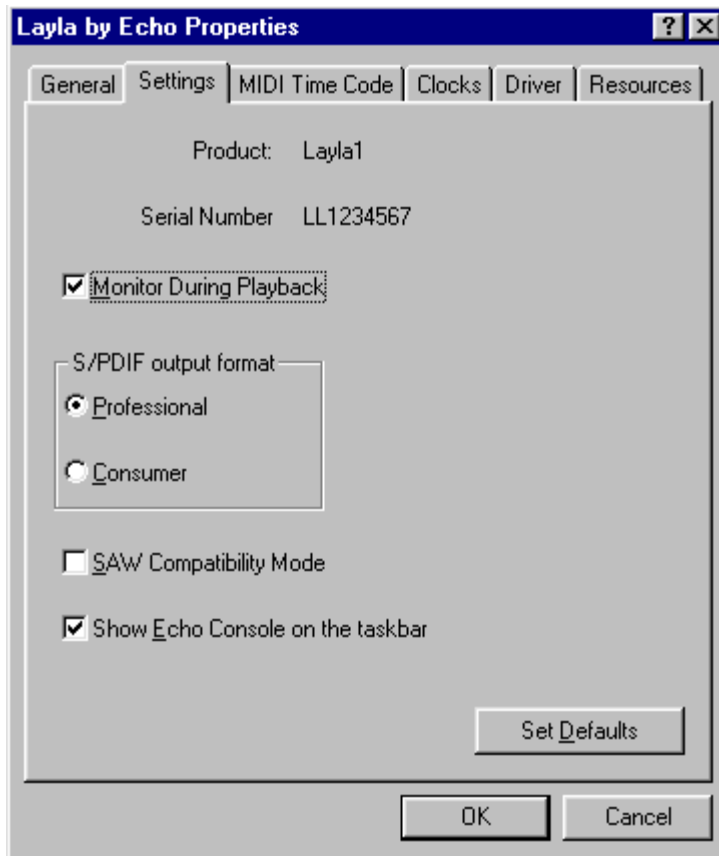

## The “Monitor During Playback” Control

In the default mode, Layla allows you to monitor your input signal whether you are recording, playing back, or simply idle. In some situations, such as when performing punch-in recording, it may be desirable to have the input signal muted until Record is enabled. In the **Layla Properties** window that appears you’ll see a checkbox labeled **Monitor During Playback**. Uncheck the box to disable input monitoring; recheck it to once again enable input monitoring. Monitoring controls are also available on the Echo Console.

## Selecting the S/PDIF Output Mode

Layla can transmit digital information in either of two modes, “professional” or “consumer.” The primary difference between the two is in the implementation of the SCMS copy-protection bit, which, in the consumer format, prevents the user from making digital copies of a digital copy.

Layla's S/PDIF output defaults to the Professional mode. If you are recording from Layla into a consumer DAT deck, the deck may not be able to recognize the signal until you switch Layla's output to Consumer mode.

We have provided a software switch in the Layla driver that allows you to select which mode Layla transmits. In the window that appears you'll see a pair of check boxes in an area labeled **S/PDIF Output Setting**: one box is labeled **Consumer** and the other **Professional**. Select the appropriate mode for your DAT (if you don't know which one to use and are having difficulties, simply try the one that is not currently checked).

Important note: Layla never transmits the SCMS bit, regardless of which mode is selected.

## **SAW Compatibility Mode**

When using Layla with the Software Audio Workshop (SAW) program from Innovative Quality Software, there are some special considerations that must be accommodated by the Layla driver. SAW expects an equal number of inputs and outputs on Layla. For SAW compatibility, the driver creates a non-functional mirror of input channels 7 and 8 (making an equal number of ins and outs). To insure that Layla will operate properly with SAW, check the box labeled **SAW Compatibility Mode**. (Note: This option should *only* be checked when Layla is being used with the SAW application.)

## **Show Echo Console on the Taskbar**

The last selection on the **Settings** screen allows you to determine whether the Echo Console program will occupy a space on the Windows taskbar (the "L" in the bottom right-hand corner of the Windows desktop).

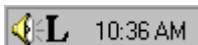

Checking this option enables this feature, unchecking it disables it.



## MIDI Time Code Settings

Now let's take a look at settings that affect performance reading MTC. Click on the tab labeled MIDI Time Code. The Properties window should now look like this:

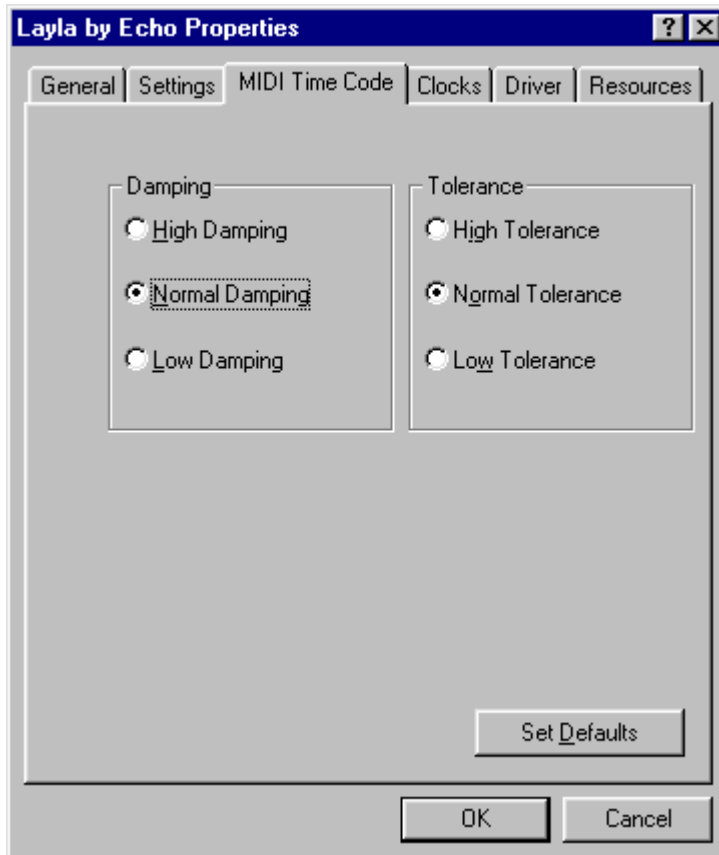

Because of the somewhat coarse resolution of MIDI Time Code, and its ability to exhibit “wow and flutter” (fluctuations in timing and consistency), the sync signal may sometimes stray from optimal. The Layla driver will automatically correct for these inconsistencies. When and how these corrections are made is configurable.

The **Tolerance** setting lets you select how far you want to allow the synchronization to stray before a correction is made. Many times, if left alone, the sync may correct itself by first straying in one direction and then going back the other way. If the tolerance is set too low, Layla will correct the synchronization too frequently. This produces frequent jumps to correct the clock, introducing jitter. If the tolerance is too high, the synchronization

will shift too far before a correction is made, which will also yield unsatisfactory results.

The **Damping** setting lets you configure how quickly the corrections described above take place. Once Layla has determined that a correction is needed, a low damping level will effect the correction rapidly. A high level of damping causes the correction to occur in a more gradual nature.

If you feel that a change is needed in the defaults for these settings because of poor MTC synchronization, it is generally wise to adjust the **Tolerance** setting first. Use the **Damping** adjustment if you are unable to obtain satisfactory results with the **Tolerance** setting.

## The Clocks Settings

Although you can set the synchronization clocks from the Echo Console, these settings are also available from the Layla Properties menu. Click on the **Clocks** tab. The window will change to look like this:

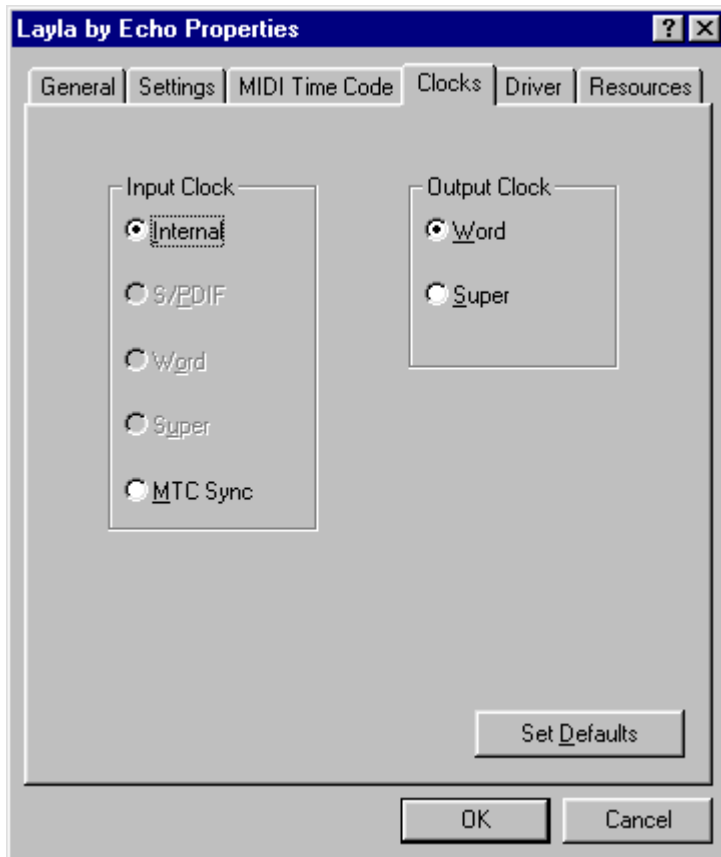

Only those clock sources that Layla determines to be available will be enabled for selection.

## ASIO Driver Installation

The ASIO driver is automatically installed on your system at the same time the Echo Layla/Gina/Darla driver is installed. To use it:

1. If you already own a copy of Steinberg's VST program, skip to step 3.
2. On the installation CD, run the program:  
**\\Audio Software Demos\Steinberg\CubaseVST demo\VSTdemo.exe**

which will install a fully functional demo of this program. What fully functional means is that all of the features are in place so you can really put the program through its paces. The only thing disabled is the ability to save. If you want save your work, you must buy the program. That's the way it works.

3. Start CubaseVST or CubaseVST demo
4. Go into menu *Audio - System*. Select the "*ASIO Echo Gina/Darla/Layla*" option in the *ASIO device* combobox.
5. Click the OK button.
6. It is best to load or create a song and verify that the driver is functioning.
7. The default latency is about 187 milliseconds using an 8k buffer. This may be changed in the dialog box found in menu *Audio - System* then select the *ASIO Control panel* button. Choose a buffer size between 1K and 64K. The smaller the buffer, the lower the latency. At 1K, the latency is 25 milliseconds.
8. You can change the data and buffer sizes in the ASIO Control panel without leaving VST provided you respond consistently to the dialog boxes. In other words, if you change the buffer size in the ASIO Control panel and select the Ok button, you must also press the Ok button in the next dialog which says:  
"*Change ASIO Device: All Fx and Bus Settings will be lost!*".  
Choosing the Cancel button will result in no more sound until you exit VST and restart it.
9. When using the ASIO driver with more than one card, you must be sure they are synched using either the Word Clock (Layla only) or S/PDIF (Layla & Gina). This involves the appropriate cabling and enabling the clocks in the console(s). See section "**The Clocks Settings**" in this manual for details. If you fail to do this, the driver will now display a warning dialog. You will not be able to continue until the problem has been corrected.
10. When running VST selecting menu *Options - Reset Devices* followed by pressing the Play button results in no sound. Simply press the *Stop* button twice to reset the position pointer to the beginning of the buffer. Then press Play and sound will resume.

## Installing Cool Edit Pro™ — Special Edition

Included with your Layla system is a special version of Syntrillium Software's Cool Edit Pro, a powerful multitrack audio recording and editing application. To install the software:

1. Insert the Layla CD-ROM.
2. Press the **Start** button, and select **Run...** from the menu. Now select **Browse...** At the top of the window that appears, you will see a box labeled **Look In:**. Clicking on this box will result in a list of your disk drives to appear. Select your CD-ROM drive. On the CD-ROM is a folder called Syntrillium; double-click on this directory to open it. Now locate the file in the Syntrillium directory called SETUP. Select this program and run it.

The SETUP program will copy all of the necessary files to your hard drive. It will also add a program group called "Cool Edit Pro – Special Edition" to the **Program** listings available from the **Start** button menu.

Cool Edit Pro – Special Edition comes with very thorough on-line manual/help, so you'll be able to get up and running with a minimum of hassles (hopefully none at all!). We do, however, suggest that you familiarize yourself with the items under the **Quick Reference** heading in the program's Help menu.

## Cool Edit Pro: Assigning Layla's Inputs & Outputs

Layla's inputs and outputs are assigned to tracks in two different ways, depending on the view—stereo waveform or multitrack—in which you are working. In the stereo waveform view, select **Options/Settings/Devices**; in the window that appears you can define the **Waveform Playback** and **Waveform Record** devices. Simply highlight the Layla inputs and outputs you wish to use in the appropriate fields. These settings will apply for all files that you play or record when in the stereo waveform view. These device settings are saved as Cool Edit Pro preferences; as such, they will be used for all subsequent sessions until you change them.

In the multitrack view, the inputs and outputs are assigned on a per-track basis. Before making assignments, however, you'll need to set up the **Preferred Multitrack Devices**. To do this, click on either of the small numeral 1s at the far left of the track display; doing so will bring up the **Playback Device** window. Click on the **Device List** button; you'll see a list of **Preferred Multitrack Devices**. In the **Playback** fields, assign Layla analog playback devices 1/2, 3/4, 5/6, 7/8, and 9/10 into the 1<sup>st</sup>, 2<sup>nd</sup>, 3<sup>rd</sup>, 4<sup>th</sup>, and 5<sup>th</sup> fields, respectively. Assign the S/PDIF playback device into the 6<sup>th</sup> field. In the **Record** fields, assign **Layla Analog Record** devices 1/2, 3/4, 5/6, and 7/8 to the 1<sup>st</sup>, 2<sup>nd</sup>, 3<sup>rd</sup>, and 4<sup>th</sup> fields respectively. Assign **Layla S/PDIF Record** into the 5<sup>th</sup> field. Click **Okay** on each window to back out to the multitrack view screen. These device assignments are saved as Cool Edit Pro preferences, and will be used each time you open a new session.

To make the playback and record device assignments for a specific track, click anywhere in the track's blue-gray area at the far left of the track display. This will open the **Track Info** window. Click on the arrows in the **Playback Device** and **Record Device** fields to select the desired inputs and outputs.

# Cool Edit Pro: Optimizing Multitrack Performance

Background mixing—the process Cool Edit Pro uses to allow a large number of tracks to play simultaneously—requires significant processing power from your computer. With larger sessions, your computer may become so occupied with mixing that you experience audio dropouts in multitrack playback. This will usually happen because the background mixing is not sufficiently complete (watch the **Mix Gauge**) before playback is initiated. There are a few things you can do to help remedy this; however, be aware that you may still have to wait for a time before hitting the **Play** button when working with very large sessions.

The settings in **Options/Settings/Multitrack** play a big part in optimizing the background mixing processes. In particular, pay attention to the **Playback Buffer Size** and the **Background Mixing Priority Level**. The key to determining how to adjust these settings is to watch the **Mix Gauge**. As a general guideline, if you notice dropouts occurring even though the **Mix Gauge** seems reasonably complete (the meter is beyond  $\frac{3}{4}$  of the way filled), try reducing the **Playback Buffer Size**, and raising the **Background Mixing Priority Level** (higher values reduce the priority level). Conversely, if you notice dropouts and see that the **Mix Gauge** is hovering around the bottom “empty”), try increasing the **Playback Buffer Size** and lowering the **Background Mixing Priority Level**.

The goal in adjusting these settings is to achieve a balance between values large enough for the program to work properly and low enough to conserve the computer’s resources. The **Background Mix Priority** must be high enough (lower settings produce a higher priority) to keep the mix ahead of playback, but not be so high as to adversely affect performance (by consuming too much of your computer’s resources). In short, the lower you can keep this setting while still keeping the **Mix Gauge** reasonably filled, the better. Raising the buffer size consumes more of your computer’s memory, so setting this too high can negatively affect performance.

When adjusting these settings, do so by small amounts, using decimal increments/decrements. Also, note that the settings will produce different results from session to session. As the number of tracks and the number of

output devices vary, so may the settings you'll need to use to maximize performance.

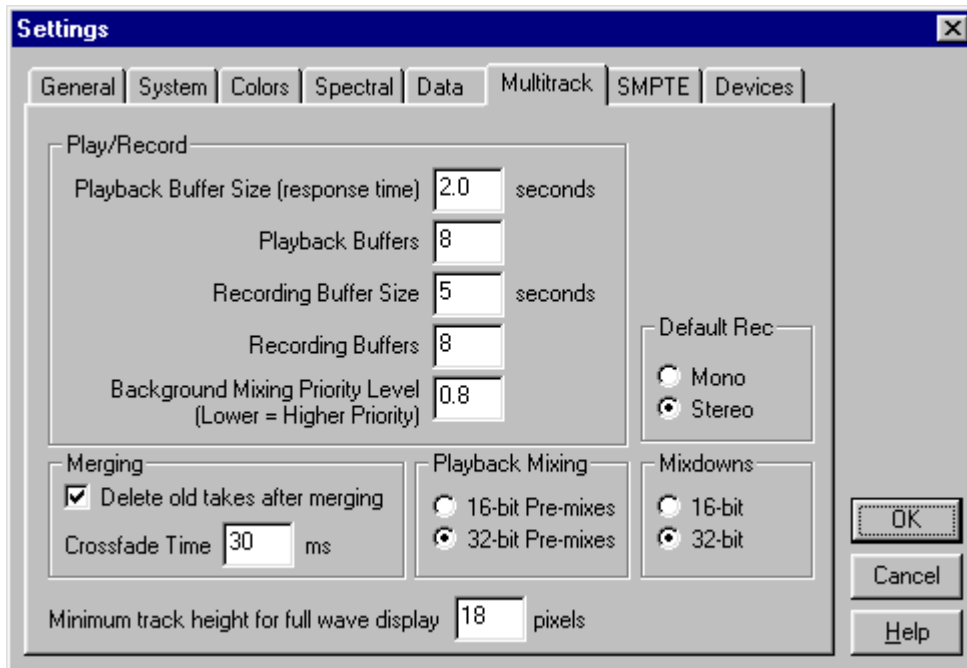

*Use the Multitrack Settings shown above as a starting place when adjusting your system to optimize the performance of Cool Edit Pro.*

Cool Edit Pro will take more time performing background mixing when you have your tracks assigned to multiple sets of Layla's outputs. In this scenario, Cool Edit Pro creates a separate mix for each output device (each Layla channel-pair). This additional mixing demands more processing power from your computer, resulting in longer mix times and possible skipping during playback. If your system is performing sluggishly, you can temporarily assign all tracks to a single channel-pair while monitoring to speed things up. When doing so, it is recommended that you check **32-bit Pre-mixes** mode in the **Settings/Multitrack** screen. When monitoring to multiple output devices, **16-bit Pre-mixes** is the recommended mode.

Note that the 16-bit and 32-bit modes are playback settings only; that is, the data on your disk remains at the resolution at which it was recorded.



## Contacting Customer Service

If you experience any trouble with your Layla system please go to the support area of our website at [www.echoaudio.com](http://www.echoaudio.com) and check out the troubleshooting FAQ's we have there. If you can't find a solution to your problem there, please fill out the provided technical support email form. This form will be sent to our technical support staff and they will respond to you quickly. **Please fill out the form completely.** We will not respond to you unless you fill out the form in its entirety. We cannot help you unless you give us the required information.

We do ask you to please read through this manual and the support area of our website before contacting us. You may find an answer to your problem using the Appendices in the Layla owner's manual and/or Cool Edit Pro's on-screen help.

Thank you for buying Layla!

Note, too, that all Cool Edit Pro — Special Edition support issues are handled solely by Echo Corporation. **Please do not call Syntrillium Software for technical support.** If you do, they will simply refer you to Echo Corporation for help.

# Appendix A: The Echo Reporter Troubleshooting Guide

After you run the Reporter program, your summary may contain one or more of the following problem/error messages. Consult the table below for suggestions on interpreting the messages and finding solutions.

<u>Message...</u>	<u>Problem...</u>	<u>What to do...</u>
* The Echo line of sound cards require Windows 95 or Windows 98	Your computer is using a Windows 3.xx or Windows NT operating system	The Echo Reporter and Layla will only operate in Windows 95 or Windows 98. You must update to one of these operating systems.
* The Echo Reporter has found that your system does not have a PCI BIOS. To alleviate this problem, please purchase a PCI system, version 2.1 or later	Your computer does not have an operational PCI Bios	Upgrade to a PCI computer with BIOS version 2.1 or higher
* The Echo line of sound cards requires PCI version 2.1 or later. To alleviate this problem, please purchase a PCI system, version 2.1 or later.	Your computer has a PCI BIOS, but it is version 2.0 or earlier	Upgrade to a PCI BIOS version 2.1 or higher
*The Echo Reporter has determined that your system has no free interrupts. The Echo line of sound cards requires one interrupt to be available for use. To alleviate this problem, try removing unnecessary or infrequently-used peripheral devices	Your computer has no free interrupts. Interrupts 0-15 are either being used or are reserved by other applications or drivers	There is no single direct solution to this problem. Generally, you will need to free an interrupt by eliminating a peripheral device. Consult Appendix C for suggestions on making an interrupt available for Layla
*The Echo Reporter has	Your computer has no	First, verify that 32-bit disk

found that none of the hard drives that were tested meet minimum performance standards with respect to transfer rate. Though your system supports the Echo line of sound cards, we recommend that you upgrade your hard drive(s), as your existing drive(s) are not capable of sustaining the minimum transfer rates required for reasonable performance

physical hard drives that test at a transfer rate better than 500Kb/second. This will seriously hinder the performance of Layla and will greatly limit the activities that you can perform.

access is enabled. This is done under the heading ***Performance in System Properties***. The only other solution is to add a faster hard disk to your system.

\*The Echo Reporter has found that your system may not be equipped with a Pentium™ (or faster) processor. The algorithm we are using for processor detection is known to return faulty values for many of the AMD, Cyrix, and other non-Intel chips, so be sure to double-check this warning against processor identification that your machine displays each time you boot up. It is essential that your machine be equipped with an Intel Pentium™ or Pentium II™ processor.

Your computer appears to have a microprocessor that is not fast enough to properly carry out the necessary operations. If your computer's microprocessor is characterized as "Pentium-class," you may want to go ahead and try working with Layla to see if your results are satisfactory.

The only way to fix this problem is to upgrade your microprocessor to an Intel Pentium™ or Pentium II™ processor.

## Appendix B: General Troubleshooting Guide

**Problem:** After installing Layla, one or more of your peripheral devices no longer functions properly.

**Solution:** During the installation of your Layla, it is possible that an interrupt conflict was created. Please see **Appendix C: Resolving Interrupt Conflicts** for more information on this topic.

**Problem:** You installed Layla and restarted Windows. Now Windows indicates that it has found new hardware and wants you to install a driver for it. This hardware was working perfectly well before you installed Layla and the driver for this hardware was already installed.

**Solution:** It is possible that during the installation process you moved an existing card from one slot to another. Windows keeps track of installed devices, not only by peripheral type, but also by physical location. In moving a card from one slot to another, Windows will no longer recognize the card as one for which a driver is installed. You must re-install the driver for the card that was moved.

**Problem:** You are unable to get your DAT recorder to recognize Layla's S/PDIF output.

**Solution:** Digital information is transmitted in either of two modes, "professional" or "consumer." The professional mode is usually implemented in devices that are likely to be used in professional recording environments, whereas the consumer mode is commonly implemented on equipment designed for home use in the consumer market. The primary difference between the two modes is in the implementation of the SCMS copy-protection bit, which, in the consumer format, prevents the user from making digital copies of a digital copy. In most professional equipment, this copy-protection bit can be turned off or on according to the user's needs. In consumer products, the SCMS bit is always enabled.

Unfortunately there is no way for the transmitting device to automatically detect which format the receiving device is able to accept. If you have a DAT deck that is not able to read the S/PDIF output from Layla, chances are Layla is transmitting in the mode that the deck is not equipped to handle.

We have provided a software switch in the Layla driver that allows you to select which mode Layla transmits. To access this switch go to the Windows **Start** button and select **Settings**. Select the **Control Panel**, double-click on the **System** icon, and select the **Device Manager** tab. Now click on the small plus sign to the left of the line labeled **Sound, Video, and Game Controllers**. To view the settings for Layla's driver, double-click on the line that says **Layla by Echo** and select the tab entitled **Settings**. In the window that appears you'll see a pair of check boxes in an area labeled **S/PDIF Output Setting**; one box is labeled **Consumer** and the other **Professional**. Select the appropriate mode for your DAT (if you don't know which one to use, simply select the one that is not currently checked). Now exit from the **Control Panel** and again try recording to your DAT.

Important note: Layla never transmits the SCMS bit, regardless of which mode is selected.

**Problem:** When the Windows start-up sound plays, it plays at an altered pitch.

**Solution:** When Layla is set to sync with an external device, it will playback at the rate generated by that device. If the startup sound you are using was sampled at 8 kHz, but you are synchronized with a device running at 44.1 kHz, the startup sound will play back at this faster rate. You have three choices - ignore the altered pitch, switch to Layla's internal clock, or use a different device for the startup sound playback. We suggest that you never use Layla for playback of any of Windows' system sounds.

**Problem:** Layla doesn't seem to recognize the synchronization clock to which it is connected.

**Solution:** Although it may seem obvious, the first thing to check is that there is a physical connection between the device generating the clock and

Layla's rack mount interface. Just because multiple devices are connected to the same computer doesn't mean they are synchronized. Next, be sure that you have selected the desired input clock source in the Console program, or made the selection on the Clocks menu in the Control Panel.

**Problem:** When trying to run sound editor software, such as Cool Edit or Cubase, the program consistently hangs, and a general protection fault error is displayed.

**Solution:** We have rarely seen this problem, but in those few instances, the installation included two or more Laylas as well as a MIDI Time piece from Mark of the Unicorn. The problem is a limitation in the maximum number of MIDI devices that Windows will allow to be installed and used concurrently. Windows 95/98 places a limitation of ten such devices.

To cure your problem, you must disable those additional MIDI devices that are being added by Layla. To do this, double-click on the "Multimedia" icon on the Windows control panel. Now select the window titled "Advanced". Locate the line titled "MIDI Devices and Instruments" and click on the small plus sign "+" to the left. You should now see the MIDI devices that are currently installed. To disable those MIDI devices that are added by Layla, simply double-click on a Layla MIDI device (MIDI for Layla by Echo), then select the option "Do not use the MIDI features on this device". You will need to disable the MIDI functionality on any remaining Layla MIDI devices that are installed.

**Problem:** Recordings made using the S/PDIF port contain occasional pops or skips.

**Solution:** When recording with the S/PDIF port, you must manually select the S/PDIF clock as the input clock. This can be done using the Console program or from the Layla Properties screen in the Windows control panel.

## **Appendix C: Resolving Interrupt Conflicts**

While Plug-and-Play™ is often called “Plug-and-Pray,” it actually works quite well most of the time. We estimate that 95% of Layla installations will go without a hitch—that Plug-and-Play will properly assign resources to your card without any conflicts. The other 5% of you will likely experience interrupt problems caused by older, non-Plug-and-Play cards that are installed in your system. These problems can manifest themselves by causing your new Layla to not function properly; in some instances, devices will fail that were previously working just fine.

If you are having problems with your computer after installing a new Layla card (or if you are unable to successfully install the card at all), please read the sections below describing what interrupts are, how they are assigned, and how to work around interrupt conflicts. Hopefully, we’ll be able to help you solve your problem without too much trouble.

### **What is an Interrupt?**

A computer has two ways of telling when a device, such as an audio card, is ready to exchange data with a program. One way is to have the computer periodically ask or “poll” the device to see if it’s ready to transfer new data. Since it is important to do the transfer as soon as it is ready, the program must poll the card quite often, which wastes the computer’s resources.

The other method is to have the card “interrupt” the program when it is ready to transfer data. It does this by sending a signal over one of the many interrupt wires connected to the slot into which it is plugged. PC’s have 16 possible interrupts (0 to 15), five of which are reserved by the motherboard for the keyboard, system timer, etc.

### **ISA and PCI Interrupts**

There are two types of expansion connectors found on today’s computers. The older style connectors are called ISA (for Industry Standard Architecture) connectors. ISA connectors have 11 of the 16 PC interrupts

wired to them. Older ISA cards (also called “legacy” cards) have you select which interrupt is used by configuring jumpers on the card. Newer Plug-and-Play ISA cards have their interrupts selected by either the computer’s BIOS (the built-in program that starts the computer) or by Windows 95/98.

The newer PCI (Peripheral Connect Interface) bus transfers data faster than ISA and was designed to support Plug-and-Play from the start. PCI connectors have only four interrupts wired to them (A, B, C, and D). However, these interrupts can be shared by more than one PCI connector slot and each connector’s interrupt can be assigned or “steered” to one of the 11 available PC interrupts by either the BIOS or Windows 95/98. As far as the user is concerned, PCI interrupts use the same numbers and are assigned the same way as Plug-and-Play ISA interrupts. Note, however, that a PCI card can share an interrupt with another PCI card but not with an ISA card.

## **Plug-and-Play and Interrupts**

When your computer first starts up, the BIOS will check each connector slot to see if a Plug-and-Play card is installed. Each Plug-and-Play card has built into it a list of what resources it requires including how many interrupts it needs and which ones it can use. The BIOS will then configure each card and, if needed, assign an appropriate interrupt. It does this for both ISA and PCI Plug-and-Play cards. Windows 95/98 will also check for and configure Plug-and-Play cards, possibly changing some of the settings to suit its needs.

## **Legacy Cards and Interrupt Conflicts**

Problems can arise when the system contains older “legacy” cards with their jumper-configured (or possibly hard-wired) interrupts. The computer’s BIOS and Windows 95/98 have no automatic way to detect these cards and determine which interrupts, if any, are being used. For example, you may have a MIDI card installed with its jumpers configured to use IRQ 9. Since the BIOS cannot detect the legacy card it will consider IRQ 9 to be a free interrupt. Consequently, it may assign IRQ 9 to Layla. The next time you try



and use your MIDI card or play back audio via Layla, neither device will function properly.

Or, maybe you have a SCSI card that had previously been assigned to IRQ 10. The BIOS may now decide to assign IRQ 10 to Layla, and move the SCSI card to IRQ 9. An interrupt conflict now exists between the SCSI card and the older MIDI card. In this case, you're probably cursing at your new card (and possibly us) for messing with your SCSI interface—after all, everything worked fine before the new card was installed. Since we're quite sensitive about being yelled at, we want to help you resolve any conflicts (of the interrupt variety) you may be having.

## **Resolving Interrupt Conflicts**

Although there is no way to automatically detect legacy interrupts, Windows 95/98 and some BIOS's allow you to reserve specific interrupts for legacy use. Once an interrupt is reserved it will not be assigned by Plug-and-Play to another card.

The first thing to do if you think you have an interrupt conflict is to determine which interrupt and which legacy card is causing the problem. To do this, run the Reporter software that came with your Layla card. For now, you can skip over the hard disk performance test since it has nothing to do with interrupts. Once the Reporter has finished the diagnostic routine, it will provide you with a list of all of the interrupts that Windows 95/98 recognizes are in use and the cards or resources to which they are assigned. Write down the interrupts that are listed and the devices that are assigned to them. Pay particular notice to the interrupt to which Layla is assigned.

Once you know which interrupt your Layla is trying to use, you need to locate which legacy card is potentially causing the conflict. To do this you will need to dig out the manuals for whatever cards are installed and examine the jumper settings to determine which interrupts, if any, are used. Hopefully, at this point you will find an offending card that was not listed by the Reporter software but is using an interrupt assigned by Windows to another device.

If you have lost your manuals and are having trouble figuring out which card may be causing a problem, you can try the brute force approach. Remove all legacy ISA cards from your system and then re-install them one at a time until the system quits working. The card that makes the computer stop working correctly will be the one that needs to be dealt with.

Once the offending card has been identified you have a few different options. One option is to simply remove the card from your system. However, you've likely got the card in there for a reason, so unless it's an old sound card you don't care about keeping, you'll probably want to use an approach to remedying the problem that allows the card to remain in the system.

Another option is to change the IRQ on the legacy card to an IRQ that isn't currently being used as reported by the Reporter program. While this may fix the problem at hand, the next time you add another new Plug-and-Play card you may wind up with another conflict. If you choose this option it is still a good idea to reserve the IRQ as described below.

## **Reserving an IRQ within the BIOS**

Other than removing the offending legacy card, the next most effective method is to reserve the IRQ for legacy use within your BIOS. To do this you will need to enter the BIOS configuration screen when your computer first starts up. This is usually done by pressing the **Delete** key or **F1** key right after the memory test during the boot-up routine. Once you're in the BIOS control panel, check to see if you are given the option of manually configuring your interrupts. Some BIOS's, such as those from Award, allow you to choose between "Plug-and-Play" and "legacy ISA" for each interrupt. If you select "legacy ISA" for the interrupt that is being used by your legacy card, the BIOS will know not to assign that interrupt to a Plug-and-Play card.

Unfortunately, many BIOS's don't support this capability. If your BIOS is one of those, don't worry: You still have another option.

## Reserving an IRQ within Windows 95/98

Windows 95/98 also allows you to reserve interrupts for legacy use. In most cases this works just as well as reserving the IRQ in the BIOS. However, you may still have problems if you boot up an older version of DOS from a floppy where Windows 95/98 can't do its Plug-and-Play magic. To reserve an IRQ within Windows 95/98 do the following:

1. Click on the **Start** button and select **Control Panel** under the **Settings** option.
2. Double click on the icon labeled **System**.
3. Select the tab labeled **Device Manager** and click the **Properties** button.
4. Select the tab labeled **Reserve Resources** and make sure that **Interrupt Request** is selected.
5. Click on the **Add** button and enter the IRQ that is being used by your legacy card.
6. Windows may prompt you that the IRQ is currently in use by another device. Click on **Details** to see which device Windows currently thinks is using this IRQ. It should be Layla or whatever device is currently conflicting with your legacy card. If that is the case, go ahead and reserve the IRQ.
7. When Windows asks, reboot your machine. When Windows restarts your Plug-and-Play cards will not be assigned to the reserved IRQ.

Hopefully, your system will now be functioning properly. If not, please refer to the "Contacting Customer Service" section of this manual. We'll do our best to help you solve your problem.

# Appendix D: An Introduction to Digital Recording

## Converting Sound into Numbers

In a digital recording system, sound is represented as a series of numbers, with each number representing the voltage, or amplitude, of a sound wave at a particular moment in time. The numbers are generated by an *analog-to-digital converter*, or ADC, which converts the signal from an analog audio source (such as a guitar or a microphone) connected to its input into numbers. The ADC reads the input signal several thousand times a second, and outputs a number based on the input that is read. This number is called a *sample*. The number of samples taken per second is called the *sample rate*.

On playback, the process happens in reverse: The series of numbers is played back through a *digital-to-analog converter*, or DAC, which converts the numbers back into an analog signal. This signal can then be sent to an amplifier and speakers for listening.

In computers, *binary numbers* are used to store the values that make up the samples. Only two characters, 1 and 0, are used. The value of a character depends on its place in the number, just as in the familiar decimal system. Here are a few binary/decimal equivalents:

<u>BINARY</u>	<u>DECIMAL</u>
0000000000000000	0
0000000000000001	1
0000000000000010	2
0000000000000100	4
0000000000001000	8
1111111111111111	65,535

Figure A. Binary numbers and their decimal equivalents

Each digit in the number is called a *bit*, so the numbers in *Figure A* are sixteen bits long, and the maximum value which can be represented is 65,535.

## Sample Size

The more bits that are used to store the sampled value, the more closely it will represent the source signal. In an 8-bit system, there are 256 possible combinations of zeroes and ones, so 256 different analog voltages can be represented. A 16-bit system provides 65,535 possible combinations. A 16-bit signal is capable of providing far greater accuracy than an 8-bit signal. *Figure B* shows how this works.

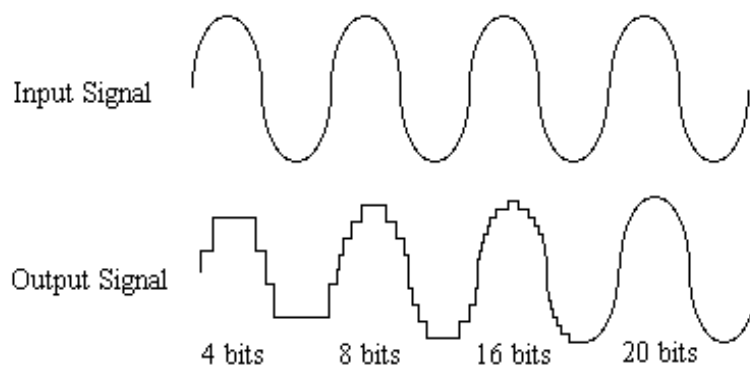

*Figure B. The more bits there are available, the more accurate the representation of the signal and the greater the dynamic range.*

Layla's analog inputs use 20-bit ADCs, which means that the incoming signal can be represented by any of 1,048,576 possible values. The output DACs are also 20-bit; again, 1,048,576 values are possible. The S/PDIF inputs and outputs support signals with up to 24-bit resolution (16,777,216 possible values). Layla processes signals internally with 24-bit resolution to insure that there is no degradation to the audio signal as it is processed through the system.

The number of bits available also determines the potential dynamic range. Moving a binary number one space to the left multiplies the value by two (just as moving a decimal number one space to the left multiplies the value by ten), so each additional bit doubles the maximum value that may be represented. Each available bit provides 6dB of dynamic range. For example, a 20-bit system can theoretically provide 120dB of dynamic range.

## Sample Rate

The rate at which the ADC generates the numbers is equally important in determining the quality of a digital recording. To get a high level of accuracy when sampling, the sample rate must be greater than twice the frequency being sampled. The mathematical statement of this is called the Nyquist Theorem. When dealing with full-bandwidth sound (20Hz–20kHz), you should sample at greater than 40,000 times per second (twice 20kHz). Layla allows you to sample at rates up to 48,000 times per second.

If the sampling rate is lower than the frequency you are trying to record, entire cycles of the waveform will be missed, and the result will not resemble the proper waveform. When the sample rate is too low, the resulting sound has diminished high frequency content.

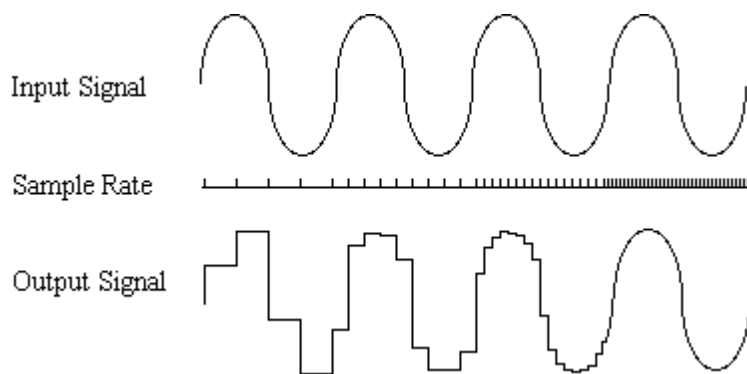

*Figure C. Increased sample rates yield a more accurate reproduction of the source signal.*

By the way, the circuits that generate the sample rate must be exceedingly accurate. Any difference between the sample rate used for recording and the rate used at playback will change the pitch of the recording, just as with an analog tape playing at the wrong speed. Also, any unsteadiness, or jitter, in the sample clock will distort the signal as it is being converted from or to analog form.

## **Storing Digital Data**

Once the waveform has been transformed into digital bits, it must be stored. When sampling in stereo at 48kHz using a 20-bit word size, the system has to accommodate 1,920,000 bits per second. Though this is a lot of data, it is well within the capabilities of personal computers.

Most computer-based digital recording systems record the data directly to the computer's hard disk. Today's hard disks are capable of storing large amounts of data, though the performance of hard drives can vary substantially. The Echo Reporter program (included on the Layla CD-ROM) will give you a general idea what the capabilities of your hard disk are and how much information it can successfully store and retrieve. The speed and size of your hard drive will be a major determining factor in how many tracks of audio you will be able to simultaneously record and playback.

# Appendix E: Specifications

## Audio Performance

Analog in to analog out

- Frequency Response: 10Hz – 22kHz,  $\pm 0.5$ dB
- Dynamic Range: 98dB
- THD+n: <0.005%, 20Hz–22kHz, A-weighted

## Hardware

- Eight ¼" TRS balanced analog inputs with precision 20-bit 128x oversampling analog-to-digital converters
- Ten ¼" TRS balanced analog outputs with high-performance 20-bit 128x oversampling digital-to-analog converters
- Outputs individually switchable between +4dBu and –10dBV
- S/PDIF digital I/O with up to 24-bit resolution
- On-board 24-bit Motorola 56301 DSP (80 MIPS)
- 24-bit data resolution maintained throughout internal signal path
- Word clock/superclock I/O
- Support for continuous sample rates with single-Hertz resolution



# Index

---

## **A**

adjusting record and playback levels · 34, 37  
analog resolution · 61  
analog-to-digital converter · 60  
appearance command · 27, 29, 30  
ASIO · 5, 43, 44  
audio connector cable · 7  
available devices · 24

---

## **B**

Background Mixing · 47  
Background Mixing Priority Level · 47  
BIOS version · 8, 50

---

## **C**

compact disk, contents · 7  
consumer mode · 39, 52  
consumer output setting · 40, 53  
contacting customer service · 49  
contents · 7  
Cool Edit Pro installation · 45

---

## **D**

damping setting · 42  
digital-to-analog converter · 60  
driver installation · 21

---

## **E**

EasyTrim · 31  
Echo Console · 26  
Echo Console controls · 30

Echo Reporter · 7, 8, 50, 51, 63  
ECHODEL.EXE · 12, 14

---

## **H**

hardware installation · 14

---

## **I**

input controls · 30  
interrupt conflicts · 52, 55, 56, 57

---

## **L**

Layla installation · 8  
legacy · 59  
legacy cards · 56, 57, 58

---

## **M**

MIDI time code · 36  
MIDI time code settings · 41  
mixer device command · 27, 28  
monitor controls · 32  
Monitor During Playback · 39

---

## **N**

new console command · 27

---

## **O**

output controls · 33

---

## **P**

PCI card, installation · 14  
PCI slots · 14  
Playback Buffer Size · 47

Playback Device · 46  
Plug-and-Play · 55, 56, 57, 58, 59  
Preferred Multitrack Devices · 46  
Priority · 47  
professional mode · 39, 52  
professional output setting · 40, 53

---

## **R**

rack mount box, cable · 7  
rack-mount box, installing · 15  
Record Device · 46  
REPORTER program errors · 50  
resolving interrupt conflicts · 55

---

## **S**

S/PDIF · 36  
S/PDIF cabling · 15, 17  
S/PDIF output mode · 39  
S/PDIF output setting · 40, 53  
S/PDIF recording · 52

S/PDIF resolution · 61  
sample rate · 60, 62  
sample size · 61  
SAW compatibility mode · 40  
SCMS copy-protection · 39, 52  
selecting a slot · 14  
software Installation · 21  
static electricity, discharging · 14  
summary screen · 11  
superclock · 36  
synchronization clocks · 34, 43  
system requirements · 7

---

## **T**

tolerance setting · 41  
troubleshooting guide · 50, 52

---

## **W**

word clock · 35